

Low cost/Coaxial type

**Z3R-Q, ZR-QX** series

# Low cost type and coaxial type transparent object detection sensor

- Long range detection at 2 m
- Uses red LED for simple light axis adjustment
- Industry standard size

Related products

High-accuracy laser

**DR-Q**  
 ● P.396

## Detection of plastic bottle passage

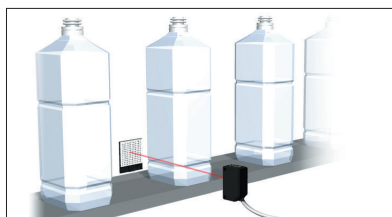

## Transparent film upper and lower limit control

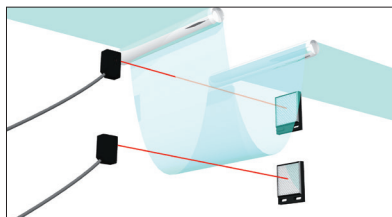

## Selection table

Type	Shape	Sensing distance	Reflector	Mounting bracket	Model (Models in parentheses are connector types)	
					NPN type	PNP type
Low cost		0.01 to 2 m	Sold separately	Sold separately	<b>Z3R-Q200N</b> (Z3R-Q200CN4)	<b>Z3R-Q200P</b> (Z3R-Q200CP4)
Coaxial		0 to 2 m	Included (P250F)	Included*	<b>ZR-QX200N</b> (ZR-QX200CN4)	<b>ZR-QX200P</b> (ZR-QX200CP4)

- A connector cable is not included in the connector type. Please purchase an optional JCN series separately.
- \*The floor-mounted BEF-W100-B is included with the cable type, and the back-mounted BEF-W100-A is included with the connector type.

## Reflectors for Z3R-Q

Standard

**V-61**
 Sensing distance:  
 0.01 to 2 m  
 60.9 × 50.9 mm

Small

**V-42**
 Sensing distance:  
 0.01 to 1.4 m  
 42 × 35 mm

Ultra-small

**V-30**
 Sensing distance:  
 0.01 to 1.2 m  
 42 × 23 mm

Side mount

**P25**
 Sensing distance:  
 0.01 to 0.7 m  
 32 × 14 mm

Vertical type

**P45A**
 Sensing distance:  
 0.01 to 0.7 m  
 54 × 12.4 mm

## Reflectors for ZR-QX

Standard

(included in ZR-QX)

**P250F**
 Sensing distance: 2 m  
 61 × 51 mm

Small

**PL20F**
 Sensing distance: 1 m  
 60 × 20 mm

Ultra-small

**PL10F**
 Sensing distance: 500 mm  
 32 × 20 mm

## Common options/accessories

Connector cables

Straight

**JCN-S**

Cable length: 2 m

**JCN-5S**

Cable length: 5 m

**JCN-10S**

Cable length: 10 m



L-shaped

**JCN-L**

Cable length: 2 m

**JCN-5L**

Cable length: 5 m

**JCN-10L**

Cable length: 10 m

Mounting bracket

For cable type  
Floor-mounted**BEF-W100-B**For connector type  
Back-mounted**BEF-W100-A**

Protective mounting bracket

- Ultra-durable 2 mm thick type
- Rust-resistant stainless steel
- Sensor is firmly secured using M3 Hex socket head cap screws
- The bracket is also firmly secured using M6 screws

**LK-S01****LK-S02**

### Can be mounted vertically or horizontally

Coaxial type: ZR-QX200□

Since the light axis of both the receiver and emitter are a coaxial structure, there is no need to take into account the sensor mounting direction or workpiece movement direction. As an LED light source transparent object detection sensor, it boasts top of the line detection stability.

Structure of coaxial type

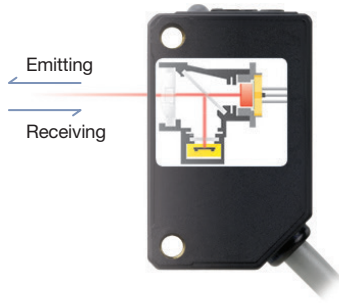

Stable detection whether standing or laying on its side

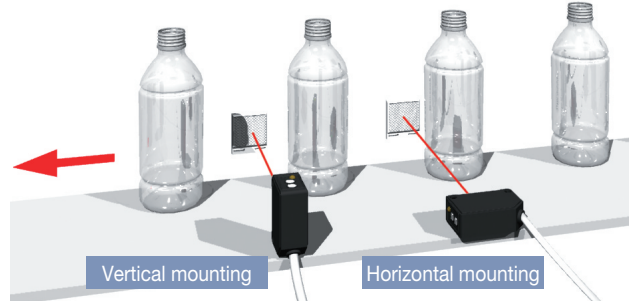

### Uses a 4 element red LED for the light source

High brightness 4 element LED: Z3R-Q200□

Because the decreases in emitted light that occur over time are low in the case of 4 element LEDs, this means that stable detection is possible over long periods of time.



### Easy adjustment of light axis

Unlike infrared light, light reflected brightly at the reflector, enabling light axis adjustments to be performed quickly.

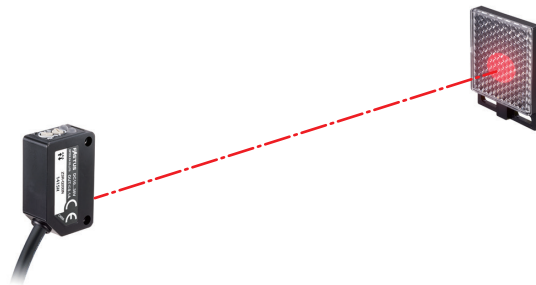

### Degree of protection: IP67, Shock resistance: 100 G

Its integrally molded structure enables all models to conform to IP67 and achieve a shock resistance up to 100 G. It doesn't break even when wet and can be used in locations where vibrations are generated.



### Standard specification size

Features an industry standard pitch of 25.4 mm.

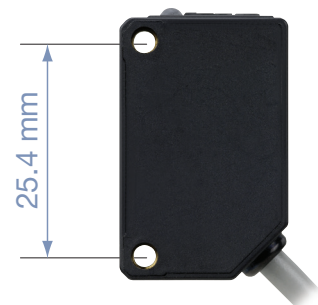

Photoelectric Sensors

Specialized Photoelectric Sensors

Laser Displacement Sensors

Transparent Object Sensors

DR-Q

Z3R-Q, ZR-QX

KR-Q, SR-Q

## Specifications

Type		Low cost	Coaxial type
Model	NPN	Cable type	<b>Z3R-Q200N</b>
		Connector type	<b>Z3R-Q200CN4</b>
	PNP	Cable type	<b>Z3R-Q200P</b>
		Connector type	<b>Z3R-Q200CP4</b>
Sensing distance		0.01 to 2 m <sup>1</sup>	0 to 2 m <sup>2</sup>
Light source		4 element red LED	Red LED
Spot size		Approx. ø140 mm (at a distance of 2 m)	Approx. ø60 mm (at a distance of 2 m)
Response time		500 µs or less	
Distance adjustment		1-turn potentiometer	
Indicators		Output indicator (orange), stability indicator (green)	Output indicator (orange)
Control output		NPN/PNP type open collector Max. 100 mA/30 VDC	
Output mode		Light ON / Dark ON selectable	
Connection type		Cable type: Cable length: 2 m ø3.8 / Connector type: M8, 4-pin	
Rating	Supply voltage	10 to 30 VDC, including 10% ripple (p-p)	
	Current consumption	20 mA or less	
Environmental resistance	Ambient temperature/humidity	-25 to +55°C (no freezing) / 35 to 85% RH (no condensation)	
	Ambient illuminance	Sunlight: 10,000 lx Incandescent lamp: 3,000 lx or less	
	Vibration resistance	10 to 55 Hz; double amplitude 1.5 mm; 2 hours in each of the X, Y, and Z directions	
	Shock resistance	Approx. 100 G (1000 m/s <sup>2</sup> ), 3 times in each of the X, Y, and Z directions	
Degree of protection		IEC standard: IP67	
Material		Housing: ABS Front cover: PMMA	
Weight without cable		Approx. 10 g	
Included accessories		None	Reflector: P250F Mounting bracket: BEF-W100-B <sup>*3</sup>

\*1. When reflector V-61 is used.

\*2. When reflector P250F is used.

\*3. Mounting bracket BEF-W100-A is included with the connector type.

● Specifications are subject to change without prior notice for product improvement purposes.

## Output circuit diagram

### Z3R-Q200□

#### ■ NPN output type

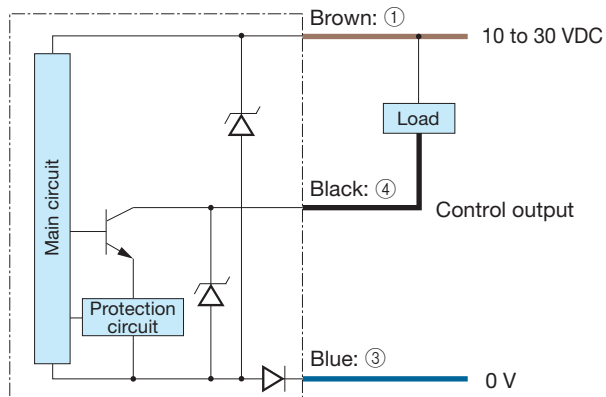

#### ■ PNP output type

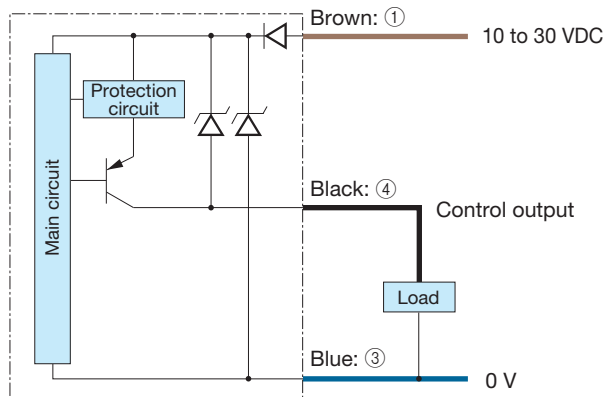

### ZR-QX200□

#### ■ NPN output type

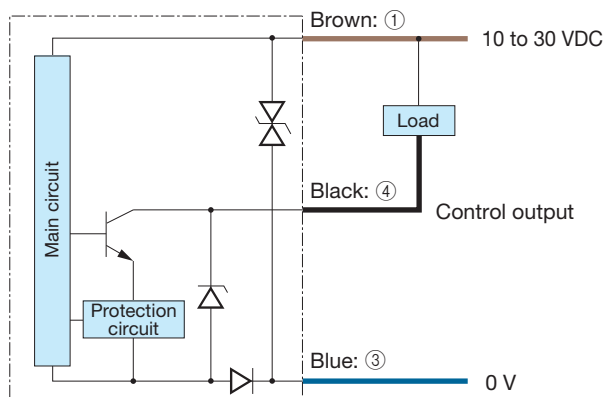

#### ■ PNP output type

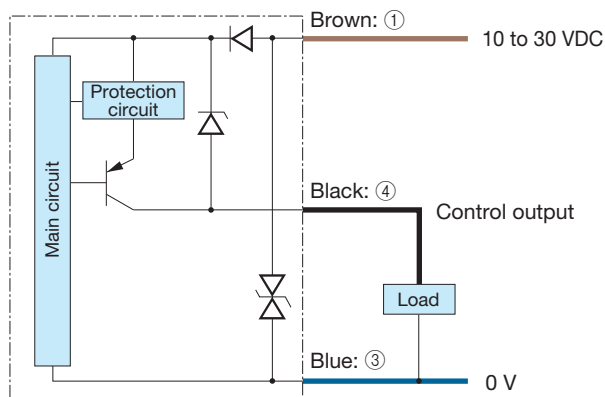

#### ■ Connector type

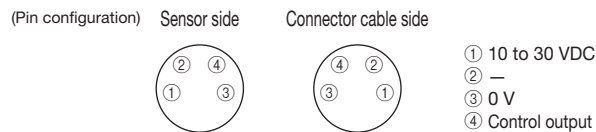

#### Connecting

■ ① to ④ are connector pin No.

#### Notes

- When using a switching regulator for the power supply, be sure to ground the frame ground terminal.
- Because wiring sensor wires with high-voltage wires or power supply wires can result in malfunctions due to noise, which can cause damage, make sure to wire separately.
- Avoid using the transient state while the power is on (approx. 100 ms).
- The connector direction is fixed as in the drawing below when you use L-shaped connector cable. Be aware that rotation is not possible.

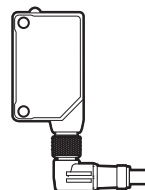

Photoelectric Sensors

Specialized Photoelectric Sensors

Laser Displacement Sensors

Transparent Object Sensors

DR-Q

Z3R-Q, ZR-QX

KR-Q, SR-Q

## Dimensions

Sensor

(Unit: mm)

■ Cable type

■ Connector type

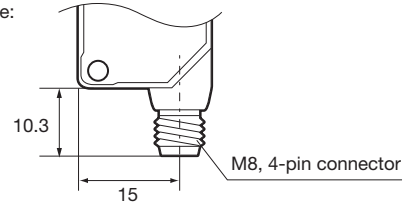
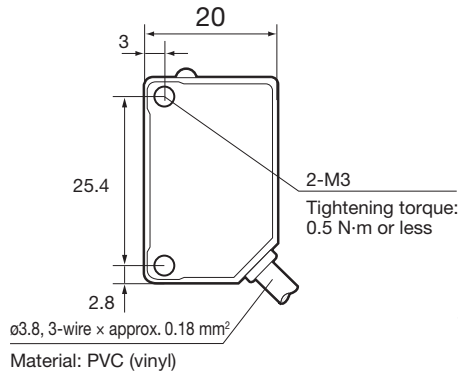
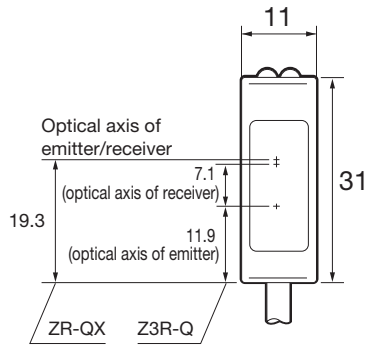
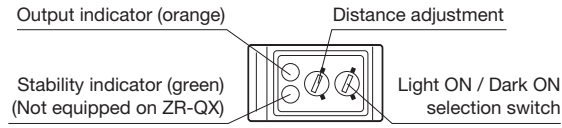

### Connector cable (optional)

■ JCN-S, JCN-5S, JCN-10S

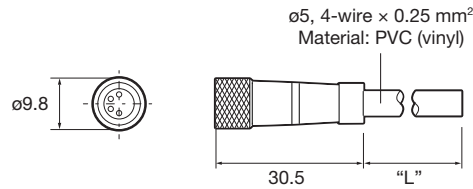

■ JCN-L, JCN-5L, JCN-10L

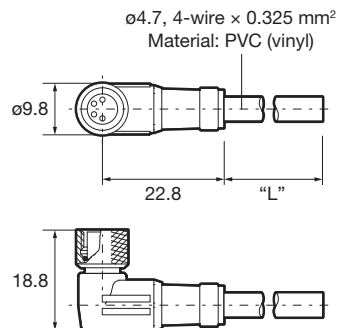

Photoelectric Sensors

Specialized Photoelectric Sensors

Laser Displacement Sensors

Transparent Object Sensors

DR-Q

Z3R-Q, ZR-QX

KR-Q, SR-Q

Mounting bracket

(Unit: mm)

■ BEF-W100-B

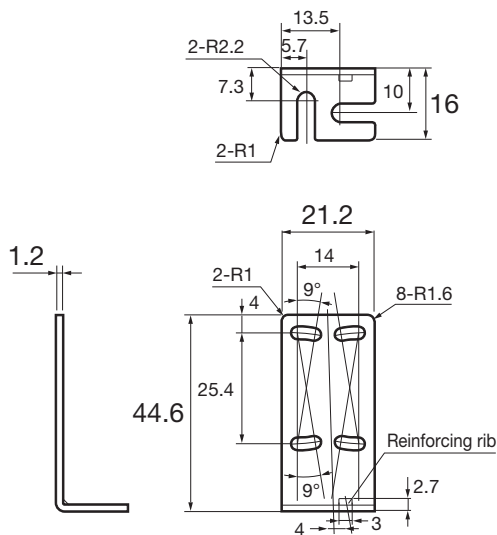

■ BEF-W100-A

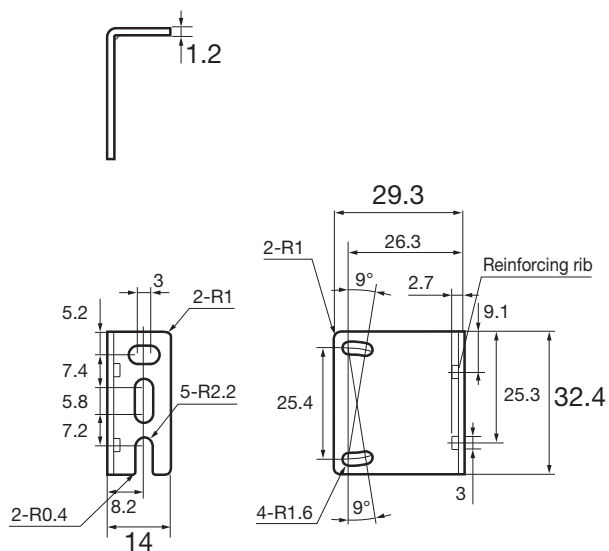

Protective mounting bracket

■ LK-S01

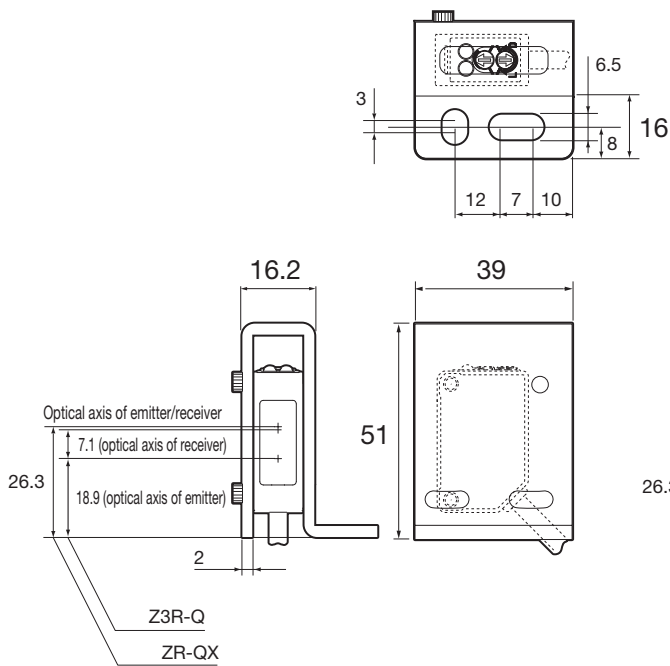

■ LK-S02

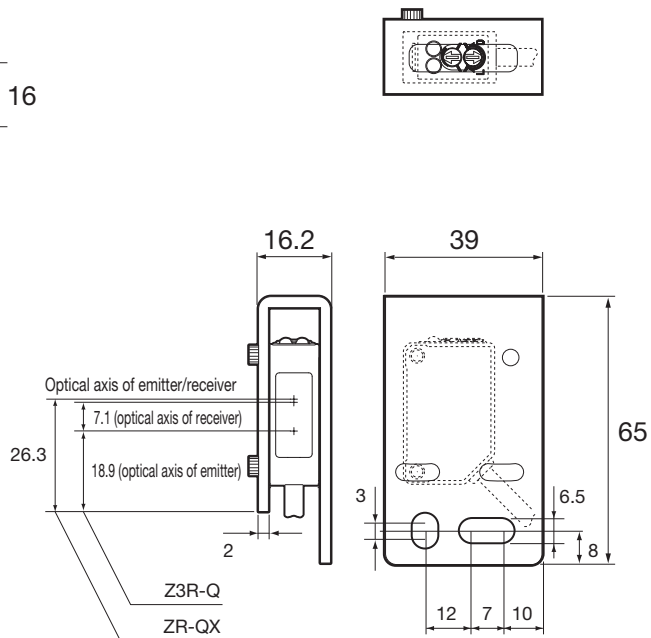

Photoelectric Sensors

Specialized Photoelectric Sensors

Laser Displacement Sensors

Transparent Object Sensors

DR-Q

Z3R-Q, ZR-QX

KR-Q, SR-Q

**Dimensions**

**Reflectors for Z3R-Q**

(Unit: mm)

■ **V-61: Standard type reflector**

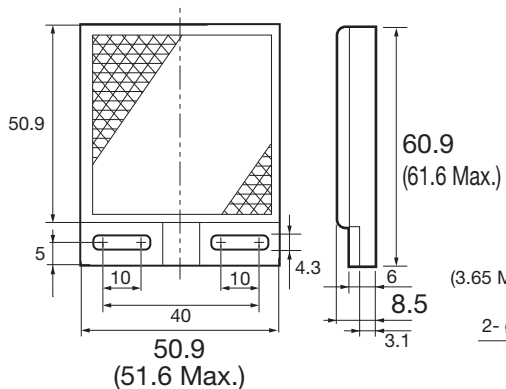

■ **V-42: Small reflector**

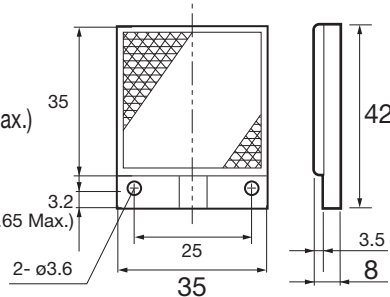

■ **P45A: Vertical type reflector**

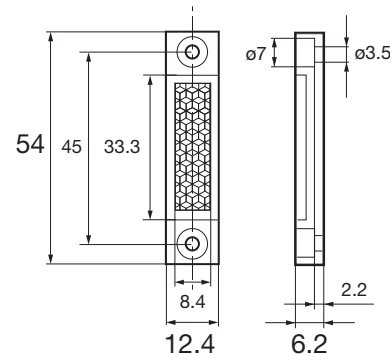

■ **P25: Side mount reflector**

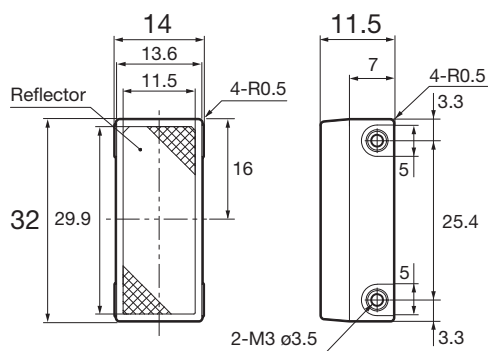

■ **V-30: Ultra-small reflector**

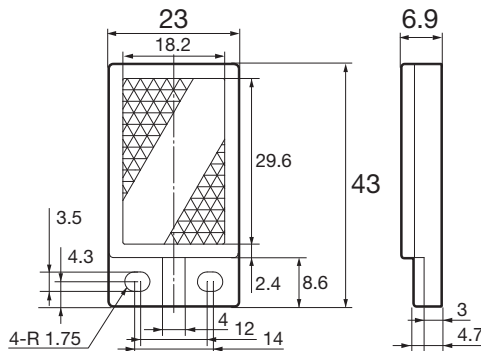

**Reflectors for ZR-QX**

■ **P250F (included)**

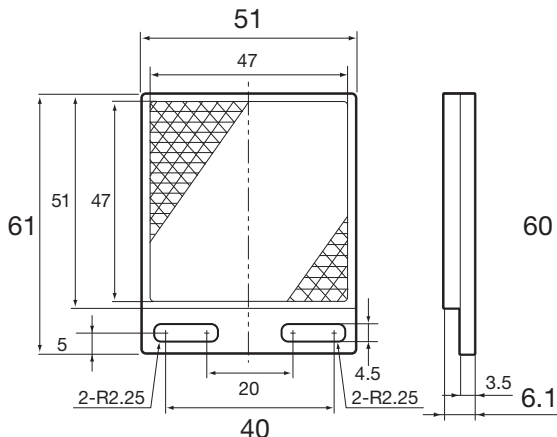

■ **PL20F (optional)**

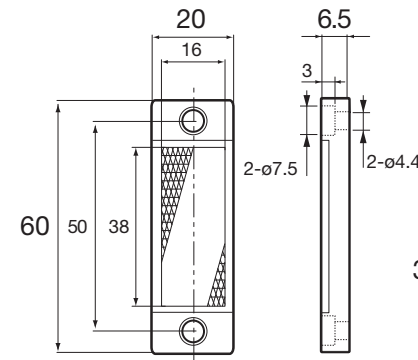

■ **PL10F (optional)**

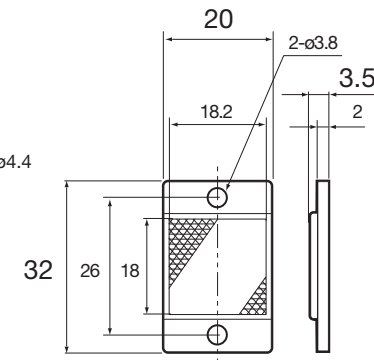

Photoelectric Sensors

Specialized Photoelectric Sensors

Laser Displacement Sensors

Transparent Object Sensors

DR-Q

Z3R-Q, ZR-QX

KR-Q, SR-Q

Typical characteristic data

Z3R-Q200

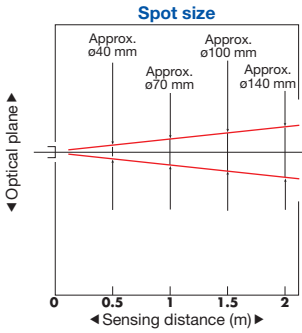
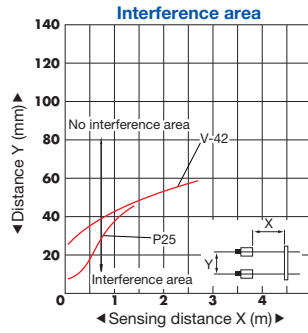
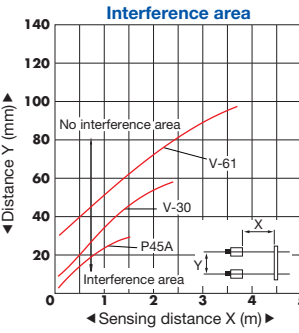
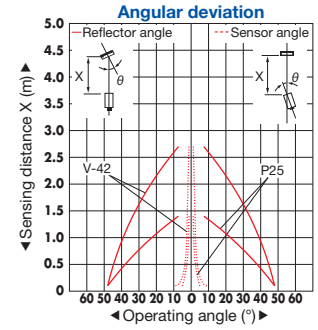
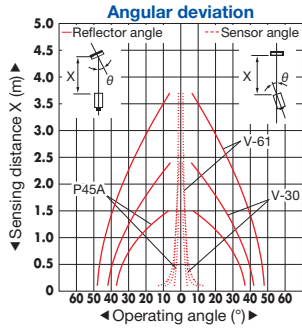
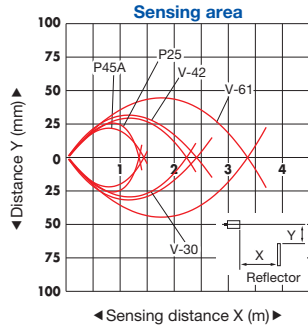
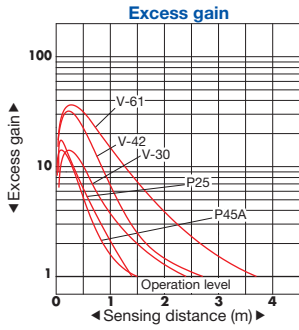

ZR-QX200

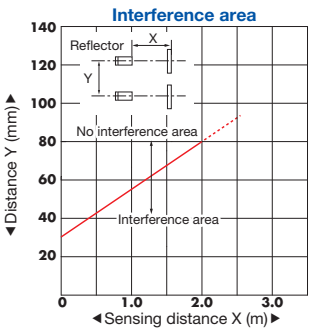
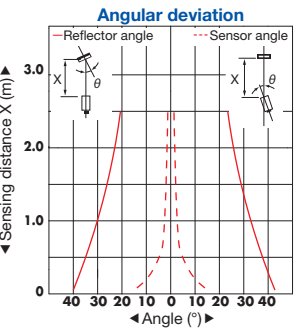
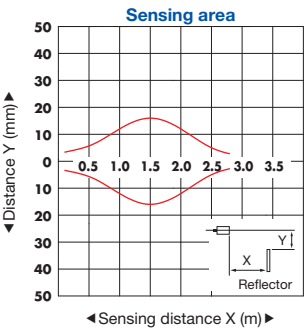
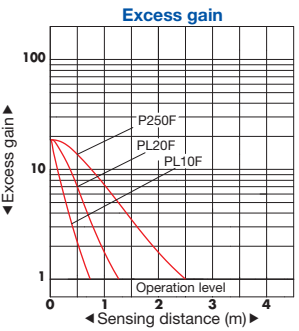

Photoelectric Sensors

Specialized Photoelectric Sensors

Laser Displacement Sensors

Transparent Object Sensors

DR-Q

Z3R-Q, ZR-QX

KR-Q, SR-Q