

NACHI

Standard specifications

EZ03V4-02/EZ03F4-02

EZ02V6-02/EZ02F6-02

[with CFDL1/L2/L4 controller]

11th edition

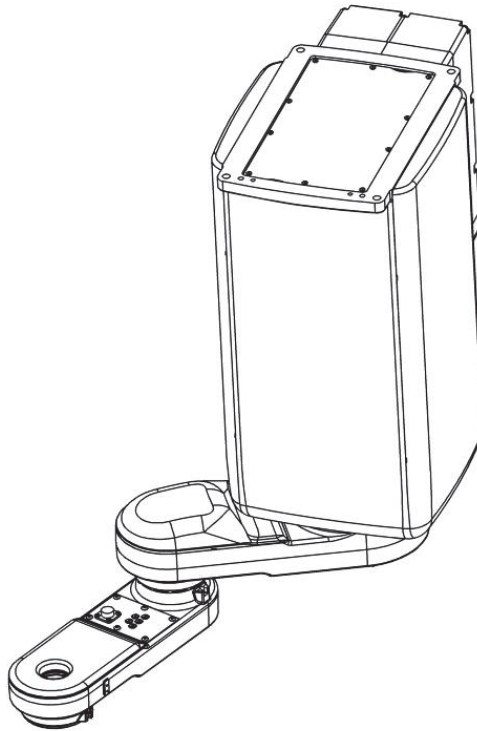

NACHI-FUJIKOSHI CORP.

1801, SEZEN-093-011, 001

Table of contents

1. Outline.....	1
2. Basic specifications.....	2
2.1 Basic specification of Robot body(4 axes)	2
2.2 Basic specification of Robot body(6 axes)	3
3. Dimensions	4
3.1 Robot dimensions and Motion range	4
3.2 Controller dimensions and Teach pendant appearance	12
4. Details of load mounting face.....	15
5. Installation procedure.....	17
5.1 Installation of Robot body.....	17
5.2 Installation of Controller	19
6. Allowable wrist load.....	21
7. Application wiring and tube diagram.....	23
8. Control specification.....	27
9. Options.....	30
10. Delivery style and service (specification which includes a robot)	34
11. Consuming power (Robot + Controller)	34
12. Paint color (Robot and controller).....	34
13. Warranty.....	34
14. Cautions.....	35

1. Outline

“NACHI ROBOT” has used mechatronic techniques, cultivated throughout the last few decades, to supply robots suited for industries utilizing welding and the material handling techniques.

“EZ03 series” is a small, simple structure, high speed, high accuracy and multi-purpose SCARA (Wing Slicer Type) robot which are optimal for assembling, material handling and other application. Because of the hollow structured arm wrist, simplified wiring from the robot body to the tool is possible. This can reduce the wiring burden of customer.

EZ series has 2 kinds of specification, one is “Ceiling installation specification” and other is “Floor installation specification”. And each type has 2 different kinds of upper and lower stroke.

In case of 6 axes specification, a 2 axes wrist unit is added on the edge of the arm.

		Z axis stroke 250mm	Z axis stroke 150mm
4 axis	Ceiling installation specification (Reach 450mm)	EZ03V4-02-4525	EZ03V4-02-4515
	Floor installation specification (Reach 550mm)	EZ03F4-02-5525	EZ03F4-02-5515
6 axis	Ceiling installation specification (Reach 450mm)	EZ02V6-02-4525	EZ02V6-02-4515
	Floor installation specification (Reach 550mm)	EZ02F6-02-5525	EZ02F6-02-5515

2. Basic specifications

2.1 Basic specification of Robot body(4 axes)

Item		Specifications			
Robot model		EZ03V4-02 -4525	EZ03V4-02 -4515	EZ03F4-02 -5525	EZ03F4-02 -5515
Construction		SCARA (Wing Slicer Type)			
Number of axis		4			
Drive system		AC servo motor			
Max. motion range	Axis 1	250mm	150mm	250mm	150mm
	Axis 2	±170 °			
	Axis 3	±180 °		±145 °	
	Axis 4	±360 °			
	Axis 5	---			
	Axis 6	---			
Max. speed *5	Axis 1	1400mm/s	1200 mm/s	1400mm/s	1200mm/s
	Axis 2	450 °/s			
	Axis 3	720 °/s			
	Axis 4	2400 °/s			
	Axis 5	---			
	Axis 6	---			
Max. pay load		2 kg (3 kg)			
Max. allowable moment of inertia of wrist *1	Axis 4	0.05 kg·m ² (Rated 0.005 kg·m ²)			
	Axis 5	---			
	Axis 6	---			
Position repeatability *2		±0.014mm			
Max. reach		450mm		550mm	
Air piping		φ6×2			
Application signal wires		10 wires			
Installation		Ceiling installation type		Floor installation type	
Ambient conditions		Temperature: 0 to 45 °C *3 Humidity: 20 to 85%RH (No dew condensation allowed) Vibration to the installation surface: Not more than 0.5G (4.9 m/s ²)			
Dust-proof / Drip-proof performance *4		IP20			
Noise level *6		70 dB			
Robot mass		42kg		43kg	

1[rad] = 180/π[°], 1[N·m] = 1/9.8[kgf·m]

- On controller display, axis 1 to 4 is displayed as J1 to J4 for each.

- The specification and externals described in this specification might change without a previous notice for the improvement

- Explosion resistance is not available.

*1: The Allowable moment of inertia of a wrist changes with load conditions of a wrist. *2: This value conforms to "JIS B 8432".

*3: Permitted height is not higher than 1,000m above sea level. If used in higher place, permitted temperature is affected by height.

*4: Liquid such as organic compound, acidity, alkalinity, chlorine or gasoline cutting fluid which deteriorates the seal material are not available to use. *5: Max. speed on the table shown is maximum value, so it changes depending on the work program and condition of wrist load. *6: A load equivalent noise level, measured according to the JIS Z 8737-1 (ISO 11201). (Operation at rated load and Max. speed)

2.2 Basic specification of Robot body (6 axes)

Item		Specifications			
Robot model		EZ02V6-02 -4525	EZ02V6-02 -4515	EZ02F6-02 -5525	EZ02F6-02 -5515
Construction		SCARA (Wing Slicer Type)			
Number of axis		6			
Drive system		AC servo motor			
Max. motion range	Axis 1	250mm	150mm	250mm	150mm
	Axis 2	±170 °			
	Axis 3	±180 °		±145 °	
	Axis 4	±180 °			
	Axis 5	±105 °			
	Axis 6	±360 °			
Max. speed *5	Axis 1	1200mm/s	1000 mm/s	1200mm/s	1000mm/s
	Axis 2	450 °/s			
	Axis 3	720 °/s			
	Axis 4	1200 °/s			
	Axis 5	720 °/s			
	Axis 6	720 °/s			
Max. pay load		1 kg (2 kg)			
Max. allowable moment of inertia of wrist *1	Axis 4	0.03 kg·m ² (Rated 0.013 kg·m ²)			
	Axis 5	0.03 kg·m ² (Rated 0.013 kg·m ²)			
	Axis 6	0.01 kg·m ² (Rated 0.001 kg·m ²)			
Position repeatability *2		±0.02mm			
Max. reach		450mm		550mm	
Air piping		φ6×2			
Application signal wires		10 wires			
Installation		Ceiling installation type		Floor installation type	
Ambient conditions		Temperature: 0 to 45 °C *3 Humidity: 20 to 85%RH (No dew condensation allowed) Vibration to the installation surface: Not more than 0.5G (4.9 m/s ²)			
Dust-proof / Drip-proof performance *4		IP20			
Noise level *6		70 dB			
Robot mass		44kg		46kg	

1[rad] = 180/π[°], 1[N·m] = 1/9.8[kgf·m]

- On controller display, axis 1 to 6 is displayed as J1 to J6 for each.
- The specification and externals described in this specification might change without a previous notice for the improvement
- Explosion resistance is not available.

*1: The Allowable moment of inertia of a wrist changes with load conditions of a wrist. *2: This value conforms to "JIS B 8432".
 *3: Permitted height is not higher than 1,000m above sea level. If used in higher place, permitted temperature is affected by height.
 *4: Liquid such as organic compound, acidity, alkalinity, chlorine or gasoline cutting fluid which deteriorates the seal material are not available to use. *5: Max. speed on the table shown is maximum value, so it changes depending on the work program and condition of wrist load. *6: A load equivalent noise level, measured according to the JIS Z 8737-1 (ISO 11201). (Operation at rated load and Max. speed)

3. Dimensions

3.1 Robot dimensions and Motion range

【EZ03V4-02-4525】Ceiling installation

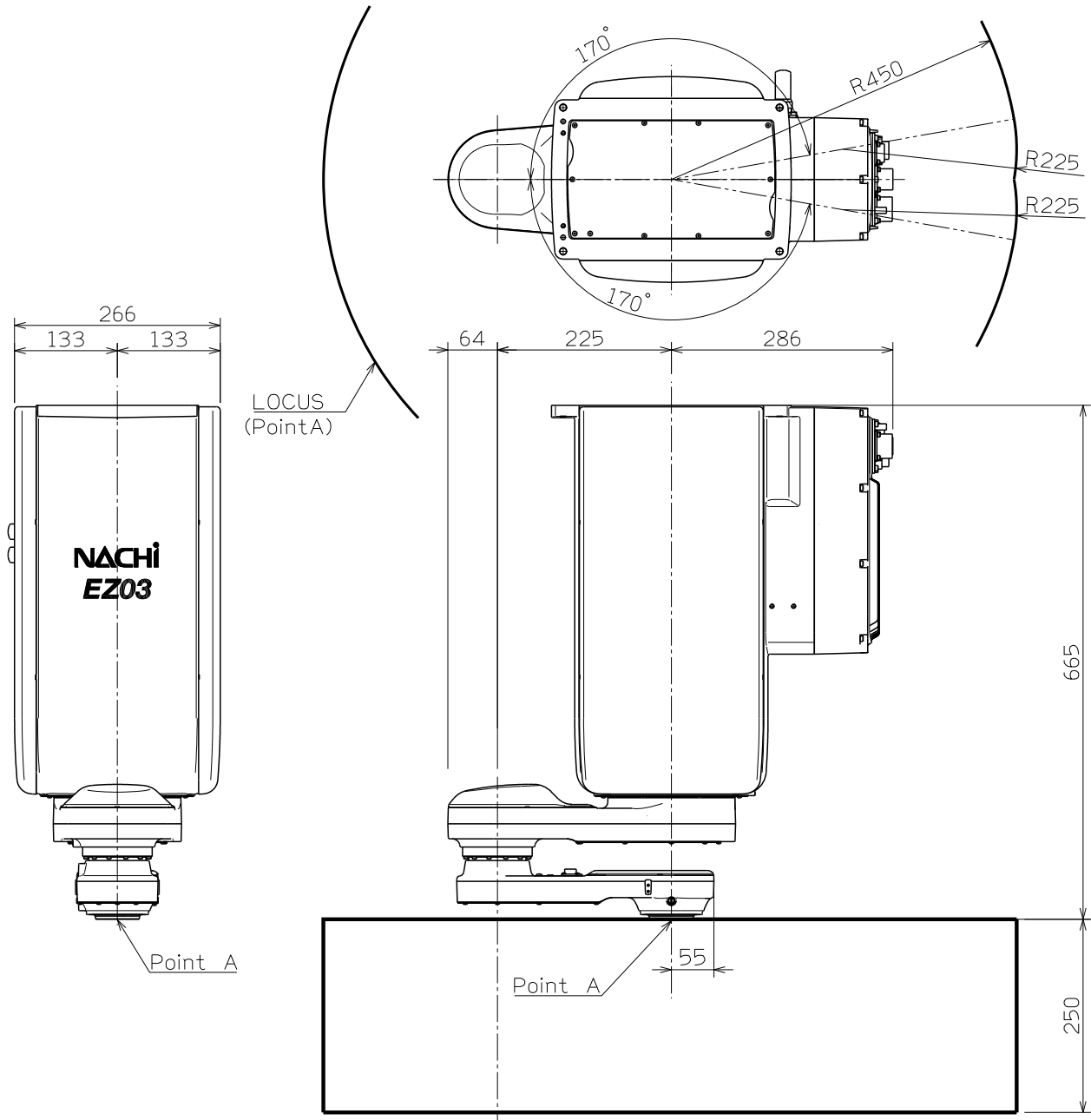

【EZ03V4-02-4515】 Ceiling installation

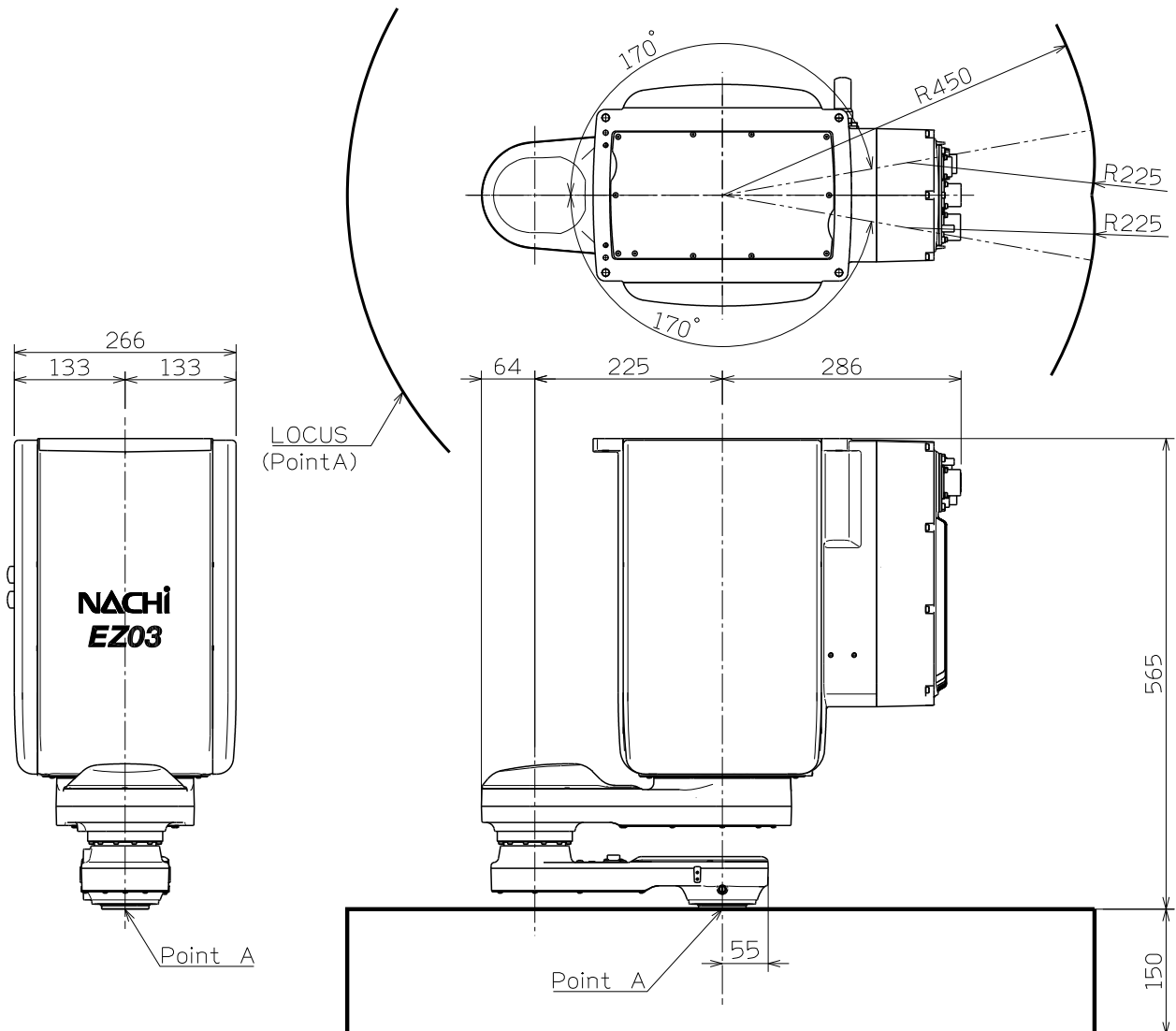

【EZ03F4-02-5525】 Floor installation

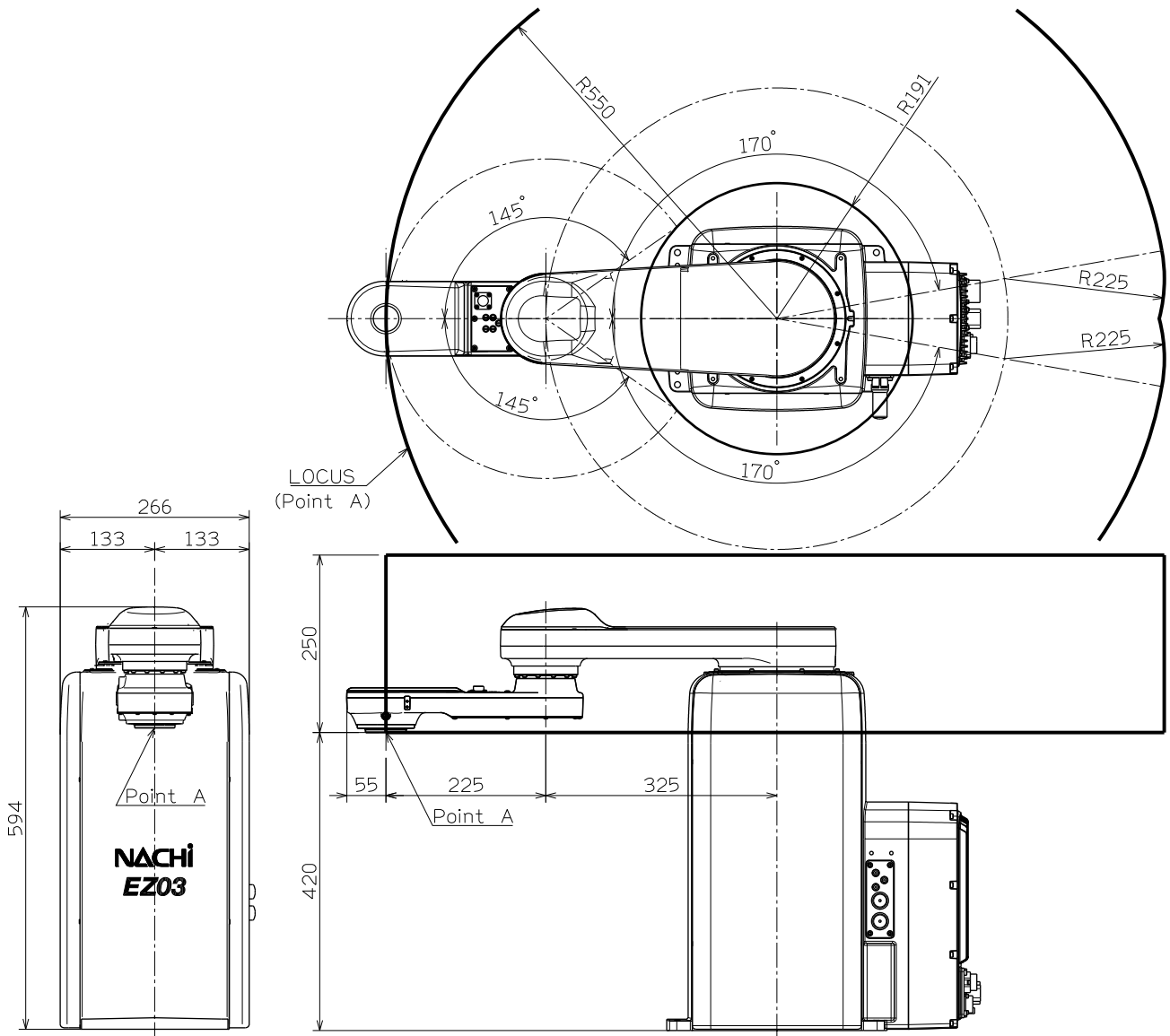

【EZ03F4-02-5515】 Floor installation

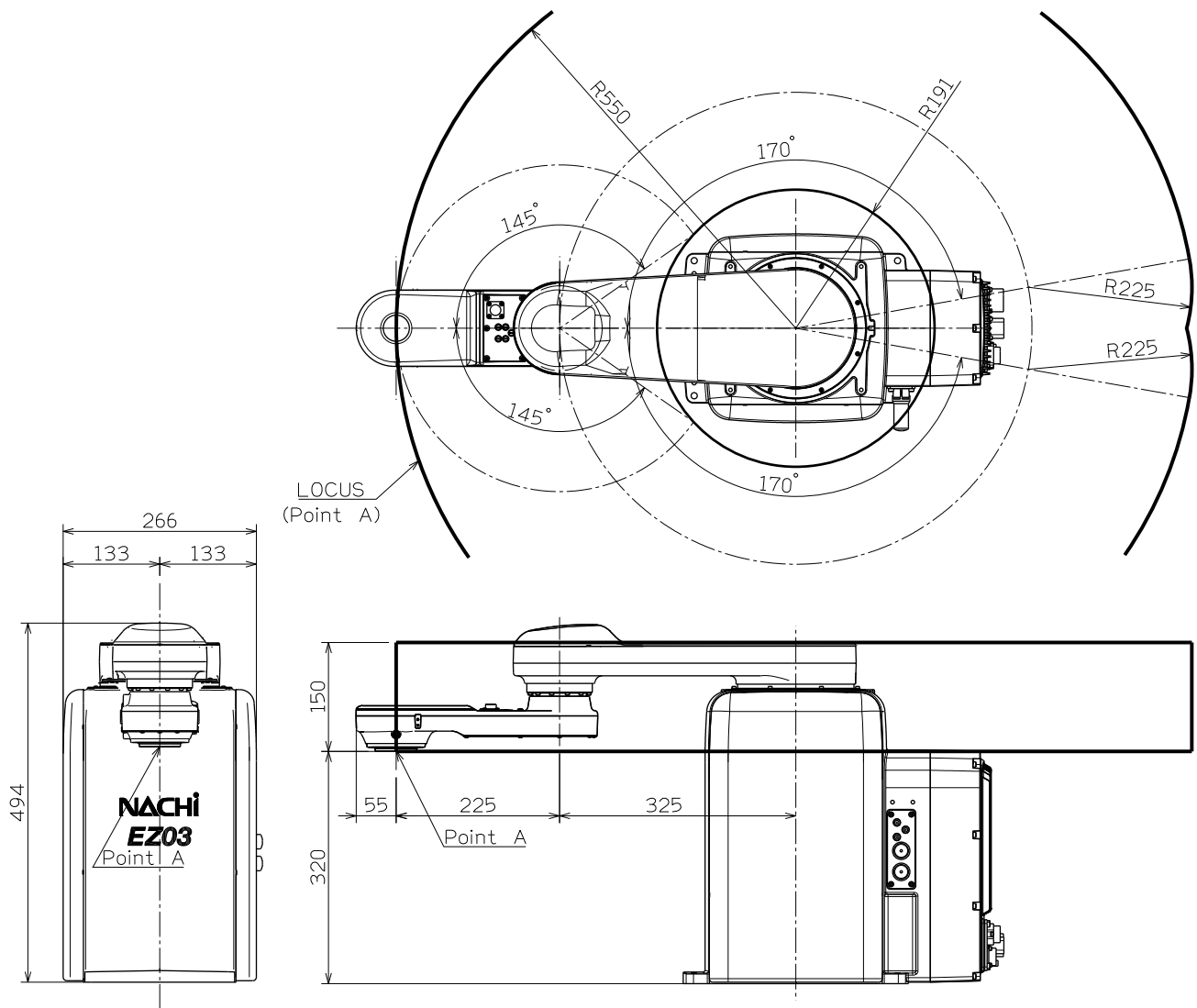

【EZ02V6-02-4525】 Ceiling installation

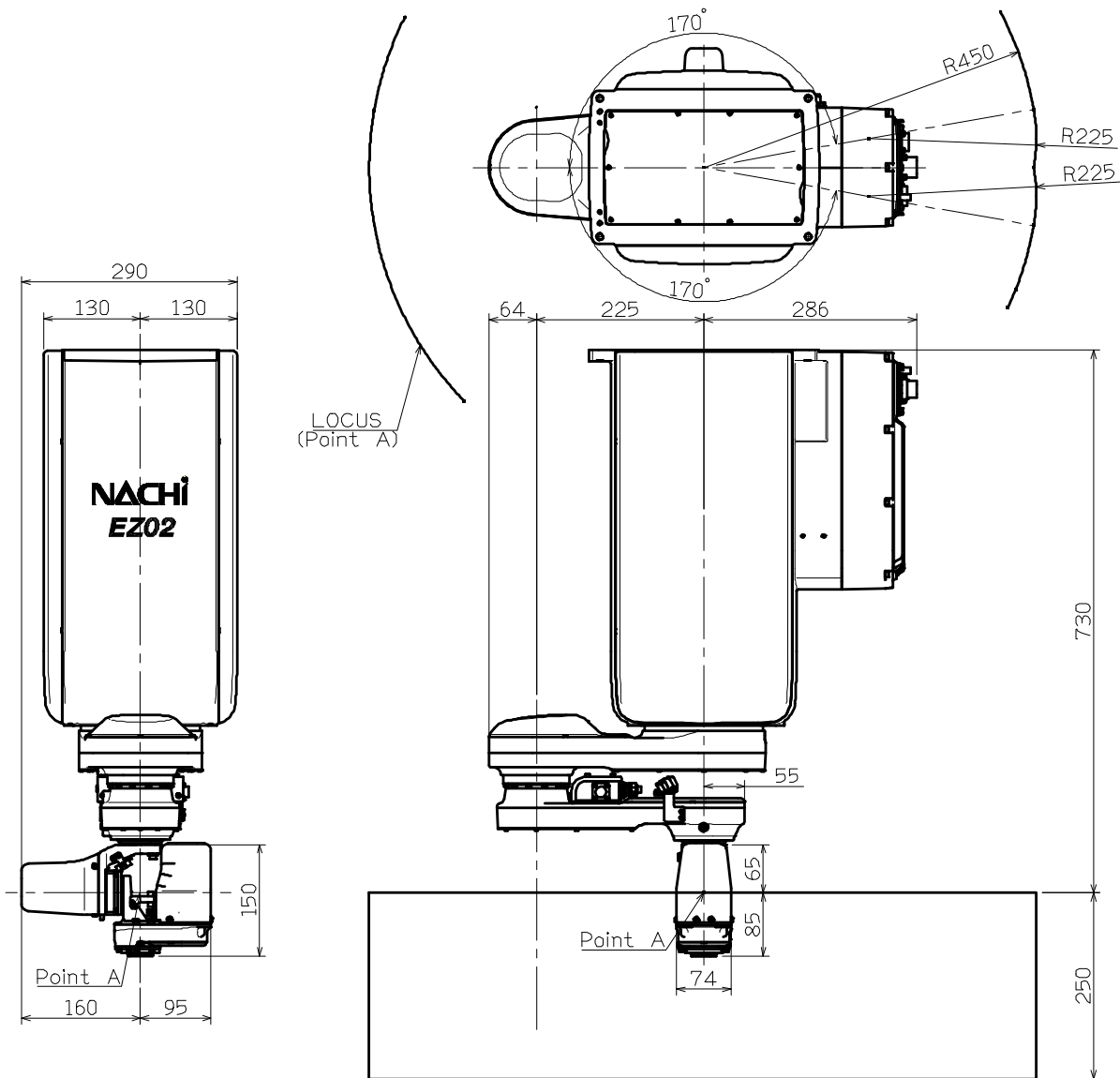

【EZ02V6-02-4515】 Ceiling installation

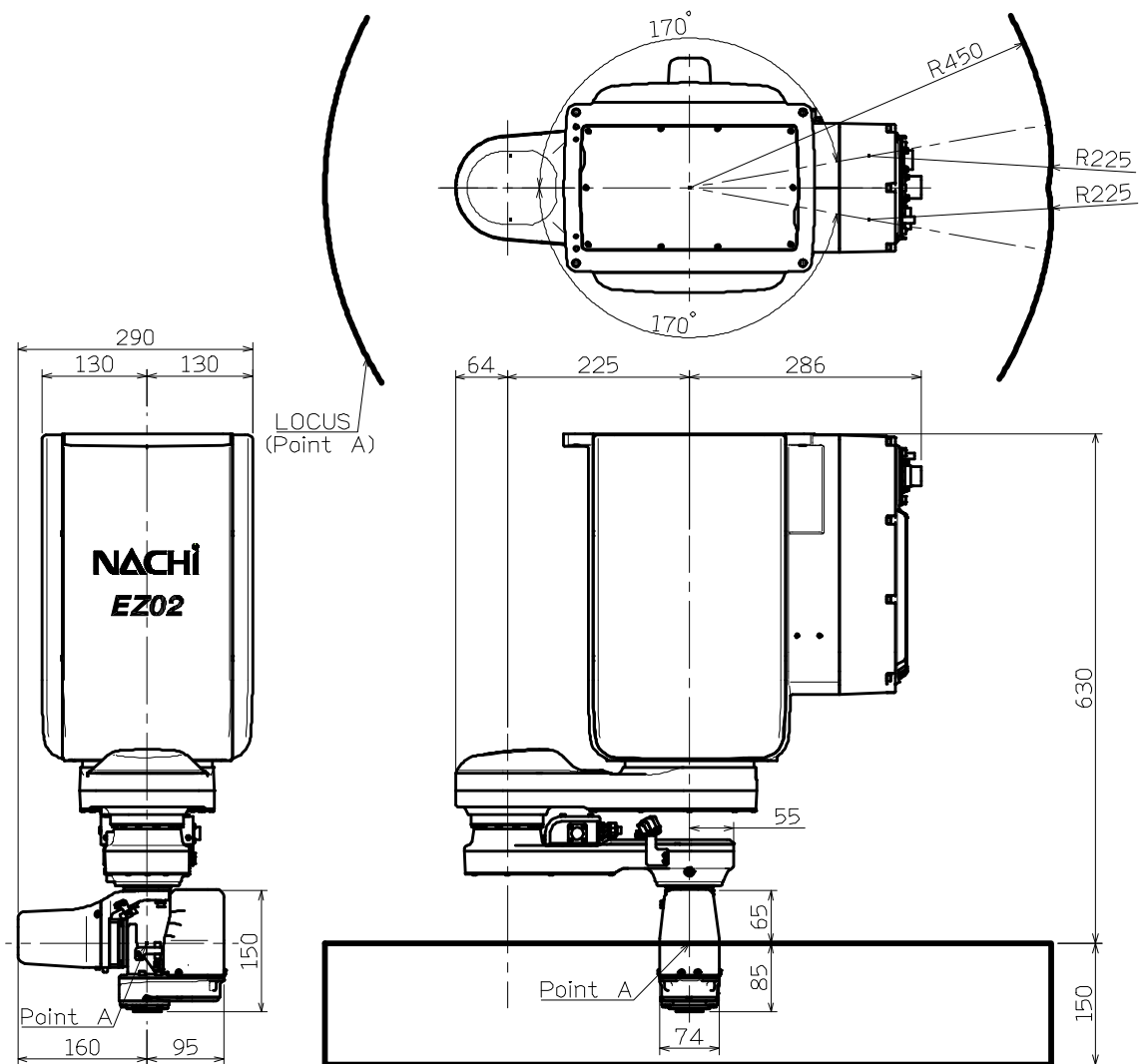

【EZ02F6-02-5525】 Floor installation

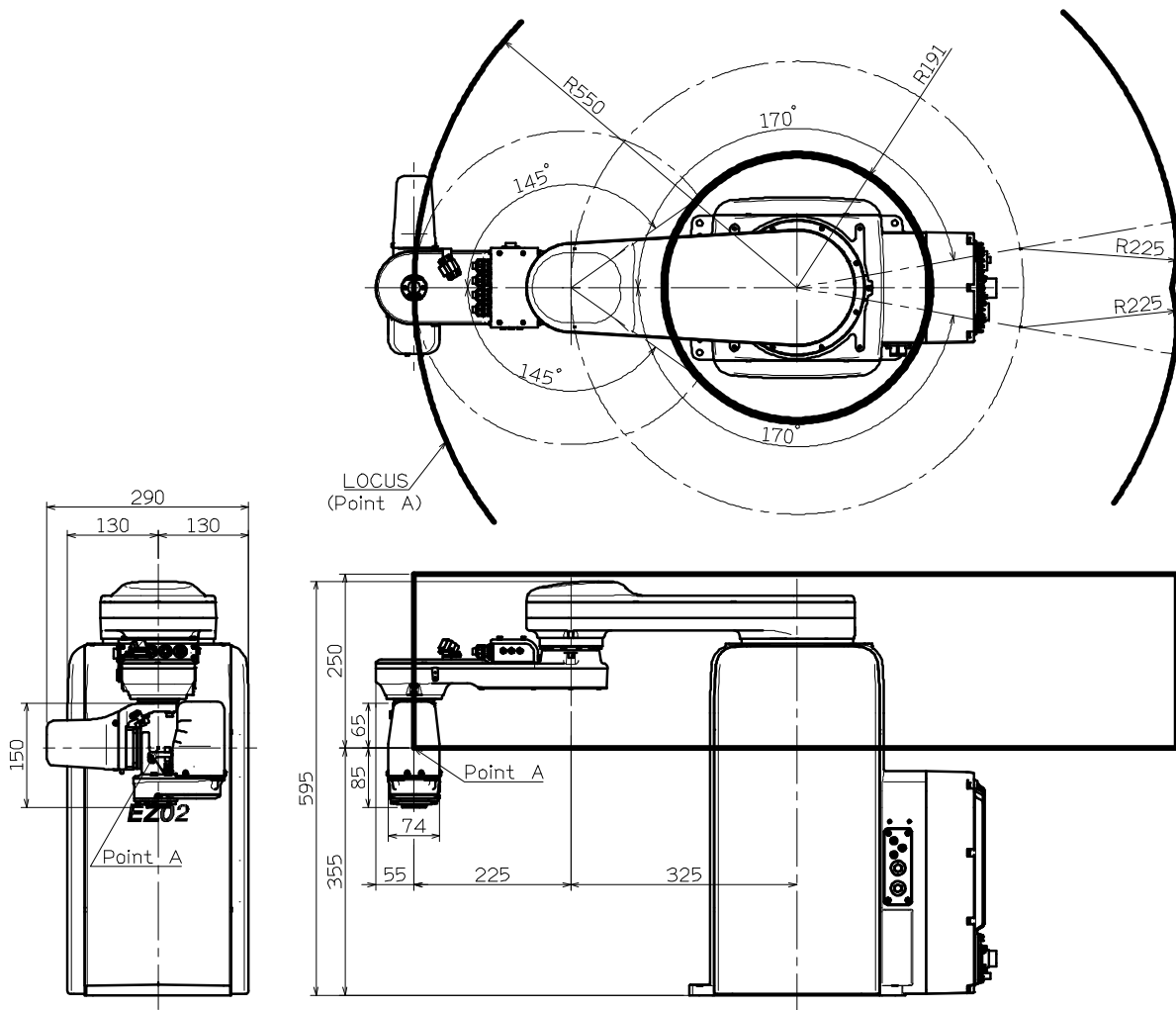

【EZ02F6-02-5515】 Floor installation

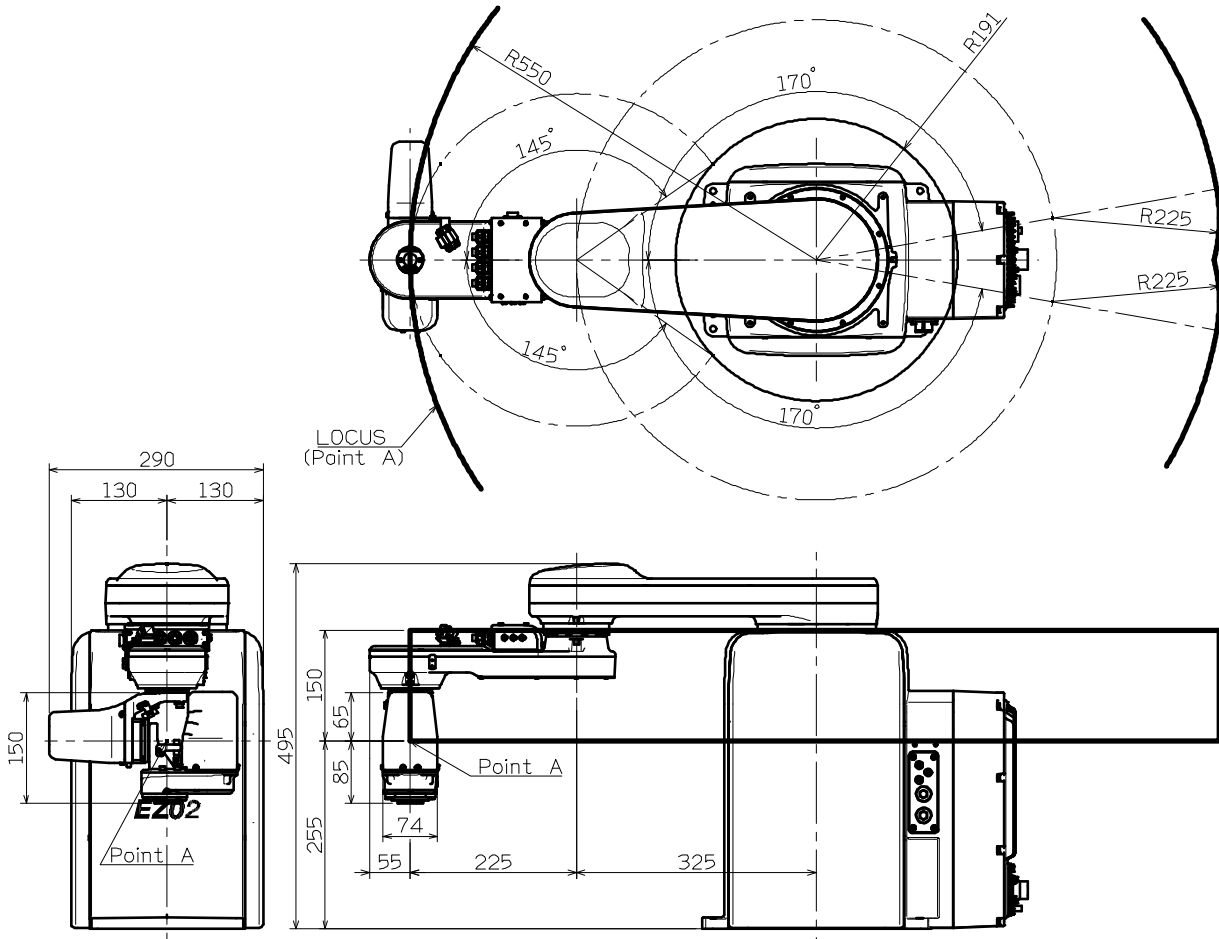

3.2 Controller dimensions and Teach pendant appearance

■ Controller cabinet
【CFDL1】【CFDL2】

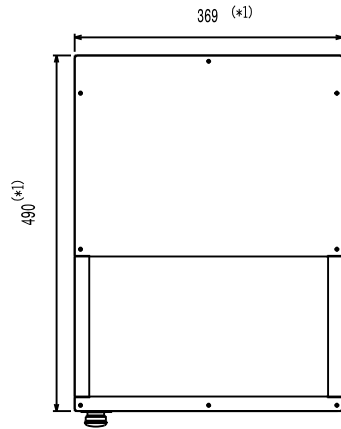

Top view

CFDL1-0000
 Number of robots = 1
 Number of option slots = 2

CFDL2-0000
 Number of robots = 2
 Number of option slots = 1

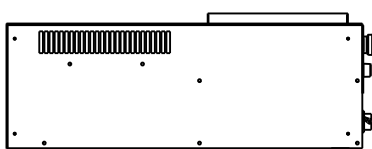

Left side view

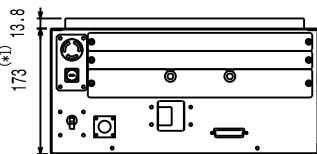

Front view

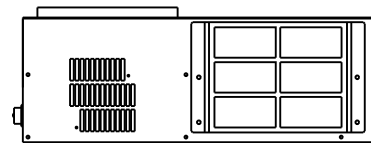

Right side view

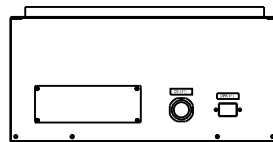

Rear view

(*1) This figure shows the box dimension. Final dimension including all of projections are
 Height 192.3mm ; including rubber foot 5.5mm
 Width 378.5mm ; including left side screw head 3.5mm + Right side filter cover 6mm
 Depth 575.0mm ; including front panel key switch 35mm (with key) + Connector on rear panel 50mm

The front view and the rear view of the CFDL2 are shown as below.

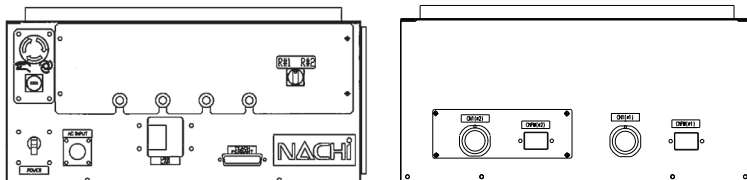

【CFDL4】

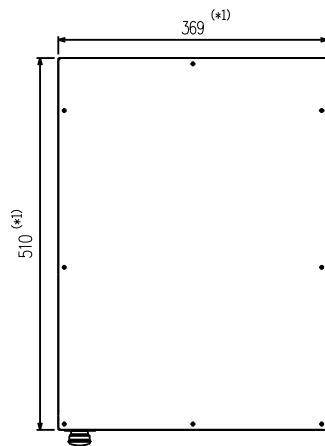

Top view

CFDL4-0000
Number of robots = 4
Number of option slots = 1
CFDL4-0200
Number of robots = 2
Number of option slots = 3
CFDL4-0300
Number of robots = 3
Number of option slots = 2

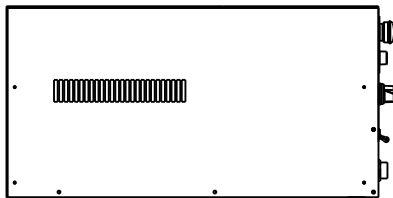

Left side view

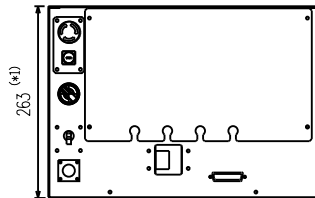

Front view

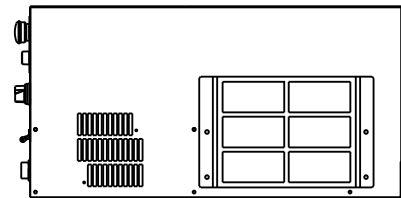

Right side view

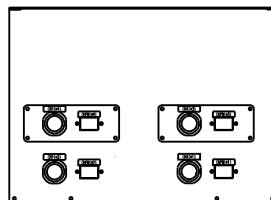

Rear view

(*1) This figure shows the box dimension. Final dimension including all of projections are
 Height 268.5mm ; including rubber foot 5.5mm
 Width 378.5mm ; including left side screw head 3.5mm + Right side filter cover 6mm
 Depth 595.0mm ; including front panel key switch 35mm (with key) + Connector on rear panel 50mm

■ High Performance Teach Pendant

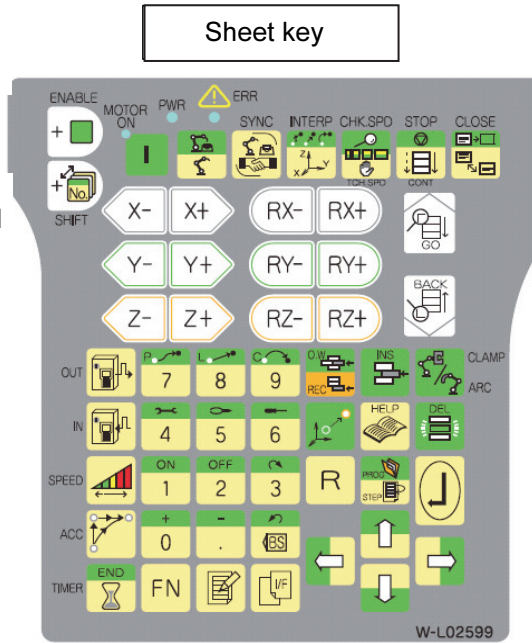
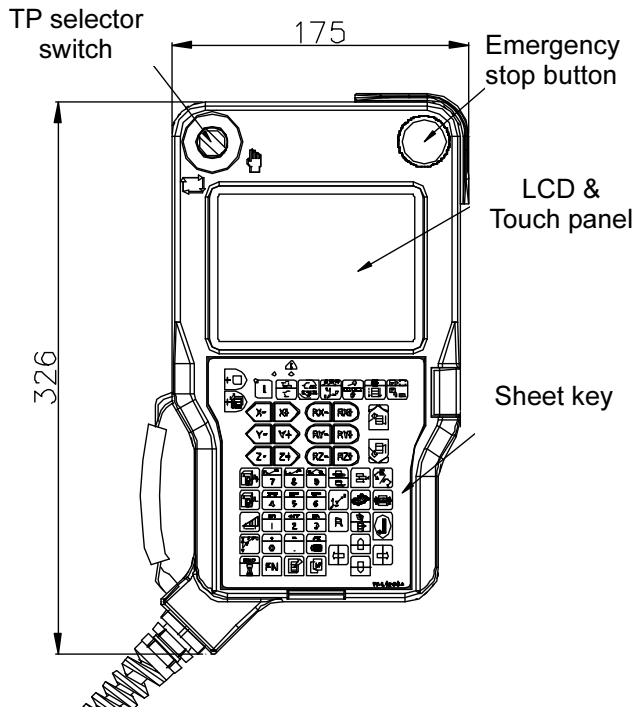



4. Details of load mounting face

For the tool fixing bolts, use the mounting P.C.D. shown in the following figures.

 CAUTION	Be sure to screw the M5 tool fixing bolts in the wrist not deeper than the screw depth in the mounting surface. Screwing the bolts deeper than the screw depth may damage the wrist.
---	--

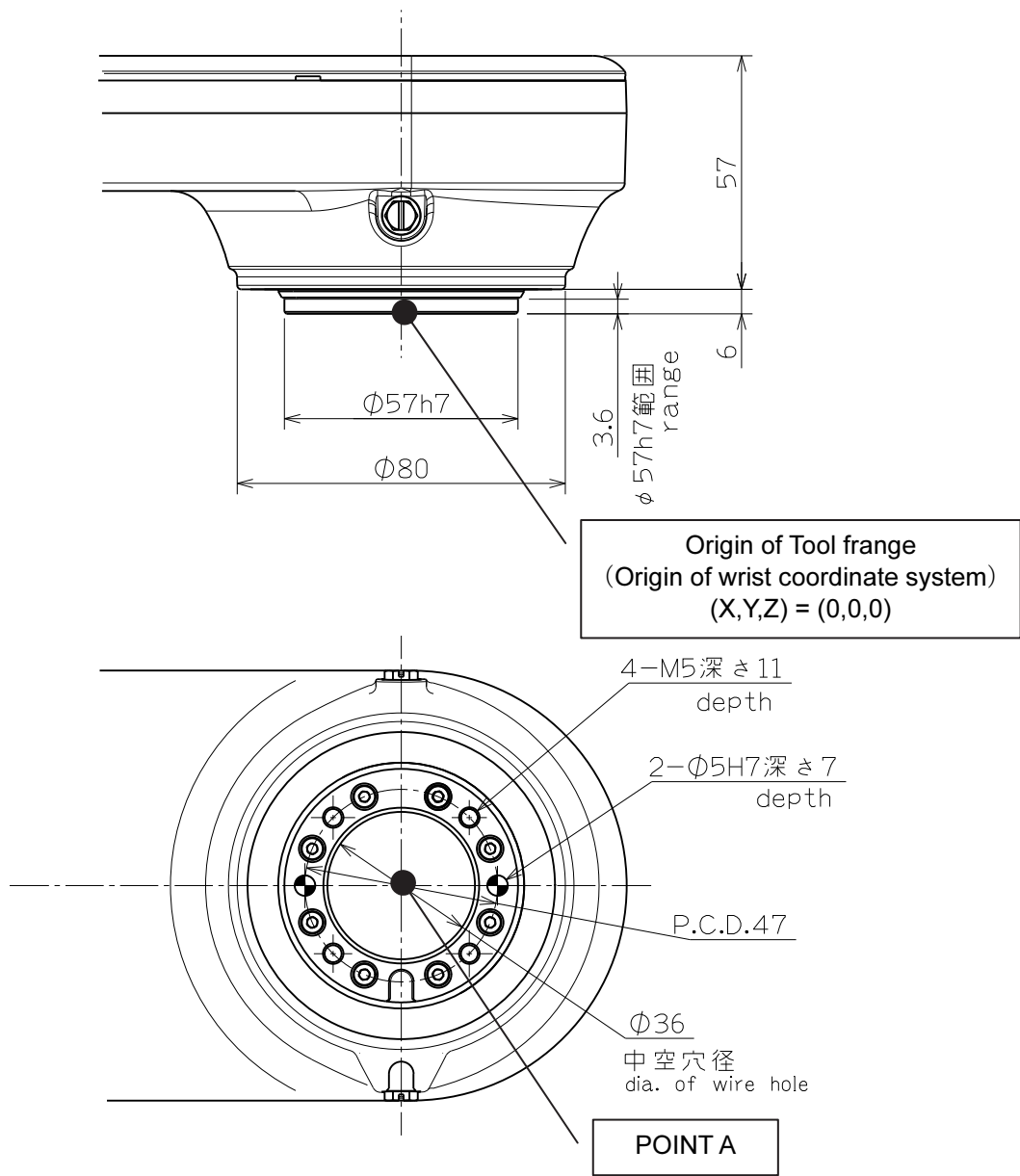
【EZ03V4-02-4525】【EZ03V4-02-4515】【EZ03F4-02-5525】【EZ03F4-02-5515】







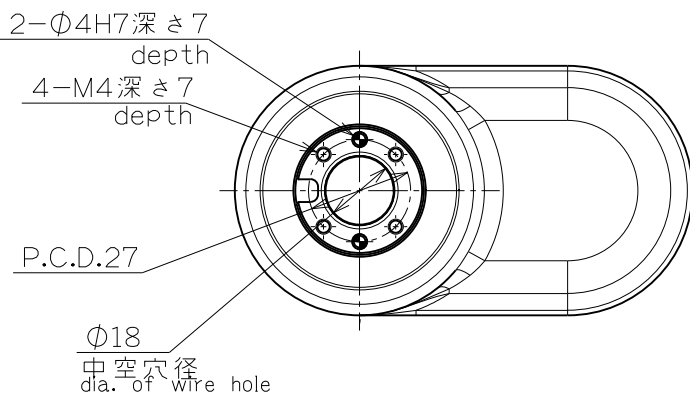
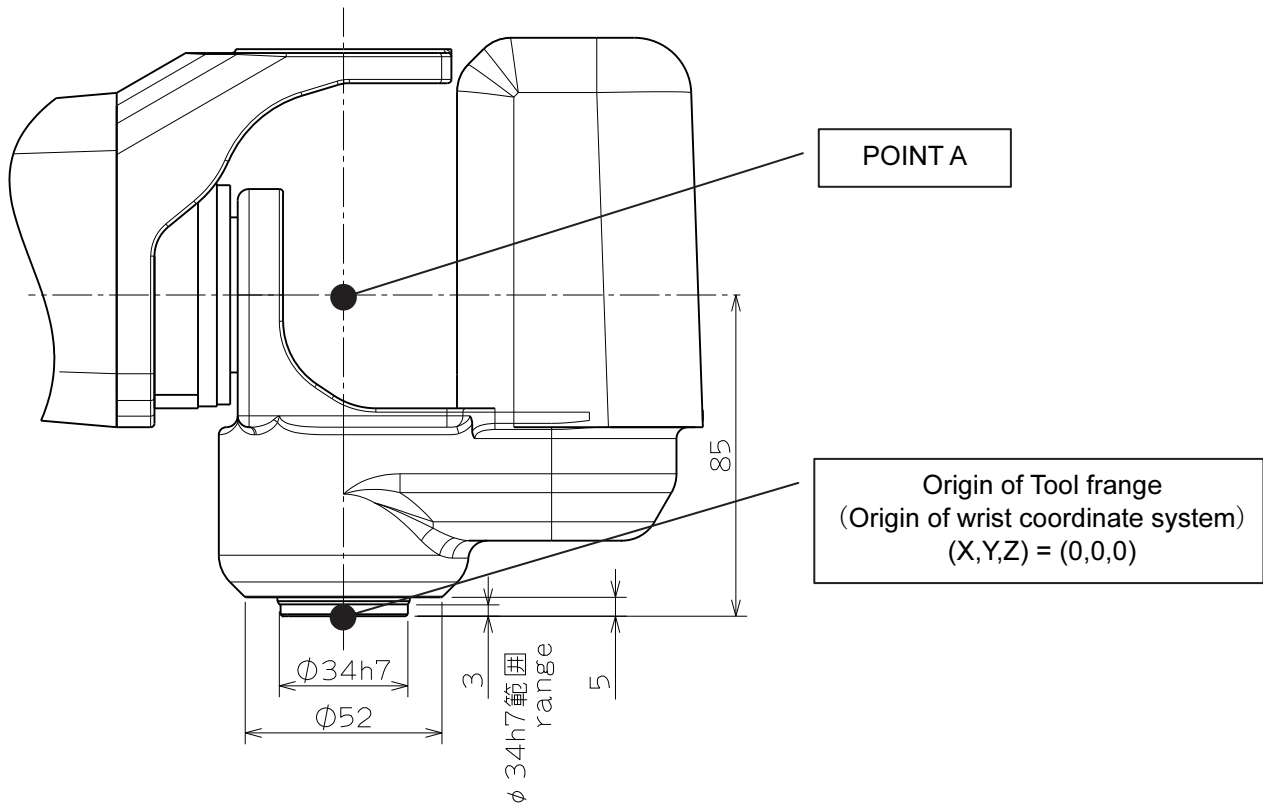

 Be sure to screw the M4 tool fixing bolts in the wrist not deeper than the screw depth in the installation surface. Screwing the bolts deeper than the screw depth may damage the wrist.

【EZ02V6-02-4525】【EZ02V6-02-4515】【EZ02F6-02-5525】【EZ02F6-02-5515】



5. Installation procedure

5.1 Installation of Robot body

 WARNING	To install the robot, it is important to position the robot so that no workers will get pinched by the robot inside or around a device to use the robot. The robot must not come into contact with any peripheral equipment when operating in the maximum operating range with a tool mounted on it.
 WARNING	Be sure to install the robot according to the specified procedure. Otherwise it will cause the robot to move or topple over while in operation, thus inducing an imminent hazardous situation.
 WARNING	To make wire connections between the robot and the controller or the peripheral equipment, fully understand the connection procedure for proper wire connections. Making wire connections according to improper procedure will cause the robot to malfunction.
 WARNING	Be sure to establish a proper grounding for the robot. If equipment such as a welder that causes substantial noises is needed to use, establish the specified grounding for the equipment.
 WARNING	During transport or installation of the robot, pay utmost care not to cause damage to wirings. Furthermore, after installing the robot, take protective measures such as using protective guards so that the wirings will not be damaged by workers or other persons, or forklift trucks or else.
 IMPORTANT	Robot is not dust-proof packaged. If robot is used in clean room, abrasive or fine particles shall be removed before carrying it in clean room. It is recommended that robot should be cleaned by swabbing with isopropyl alcohol (IPA). Use of other solvents or pure water could contribute rust or peel of coating materials.
 IMPORTANT	It is to be noted that cleanliness of robot is worse if it has operated in poor conditions for a long time or if it has been left as it was.

■ Installation location and ambient conditions

Conditions (temperature, humidity, height and vibration) are written in “Chapter 2 Basic Specifications”. Further ambient conditions listed below must be observed.

- (1) Location with the drainage structure so that swivel base is not flooded, when the liquid such as water or cutting fluid is splashed on the robot body
- (2) Location with no flammable or corrosive fluid or gas.
- (3) Type D grounding (the grounding resistance is 100Ω or less) is necessary.

■ Installation procedure

While robot moves, large reaction force is applied to the swiveling base from all directions. Consequently, the robot should be installed in such a manner that the foundation endures reaction force caused by accelerating or decelerating the speed to lock the robot, not to mention that it endures static loads. Repair uneven spots, cracks, and others on the floor, and then install the robot by following to the table below. If thickness of floor concrete is less than needed level, an independent foundation should be constructed. Inspect the foundation prior to the robot installation, and then construct the foundation, if necessary.



Thickness of floor concrete	Not less than 150mm
Installation parts *1	4 bolts of M8 X 25 (JIS: Strength class 12.9) 4 plain washers of not less than 2.3mm in thickness
Tightening torque	33.3 N·m
Allowable repeated tensile *2	Approximately 800 N

*1 : Installation parts are not accessory of robot.

*2 : This tensile is per installation bolt when robot is installed with all bolts written in table above.

■ Installation space

To install the robot, lock the swiveling base of the robot.

 WARNING	The mechanical stopper end is located in a position exceeding the specified motion range (software limit) of axis 2. To install the safety fence, with consideration given to the wrist configuration and the shape of tool.
 WARNING	On axis 2, the robot motion range can be regulated for safety. Optional part is necessary to enable this function.

- 【EZ03V4-02-4525】
- 【EZ03V4-02-4515】
- 【EZ03F4-02-5525】
- 【EZ03F4-02-5515】
- 【EZ02V6-02-4525】
- 【EZ02V6-02-4515】
- 【EZ02F6-02-5525】
- 【EZ02F6-02-5515】

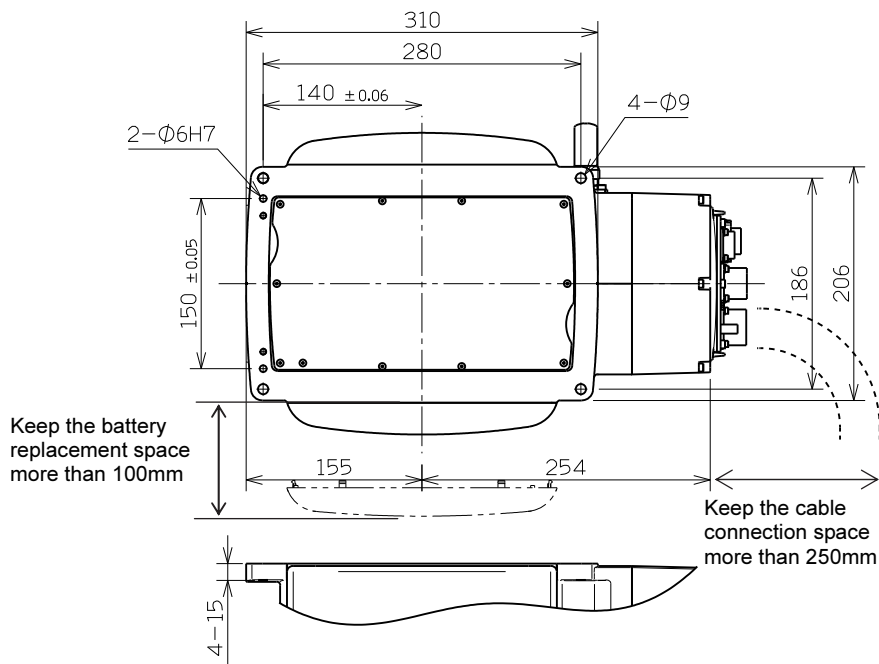

■ Accuracy of installation surface

When installing robot, strictly observe precautions listed below to cause no distortion on the base.

- (1) Make the deviation from the flatness of the 4 plates on the robot installation surface fall within 0.1 mm.
- (2) Make the deviation in height between the 4 places of each base plate installation surface and the robot installation surface fall in the range of 0.1 mm (± 0.05 mm).



■ Maximum robot generative force

Robot model	Maximum Vertical generative force F_V	Maximum horizontal generative force F_H	Maximum Vertical generative moment M_V	Maximum horizontal generative moment M_H
【EZ03V4-02-4525】 【EZ03V4-02-4515】 【EZ03F4-02-5525】 【EZ03F4-02-5515】 【EZ02V6-02-4525】 【EZ02V6-02-4515】 【EZ02F6-02-5525】 【EZ02F6-02-5515】	700N	500N	200Nm	200Nm

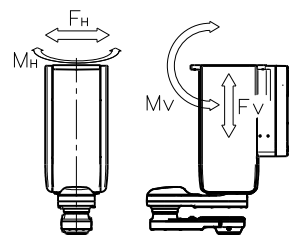

5.2 Installation of Controller

Keep a clearance of at least 200 mm between the controller and the wall behind it in order to ensure proper ventilation. CFDL1/L2/L4 controller is not dust-proof drip-proof. If dust-proof and drip-proof is necessary, controller protection BOX (option) is necessary to use.
【CFDL1】【CFDL2】

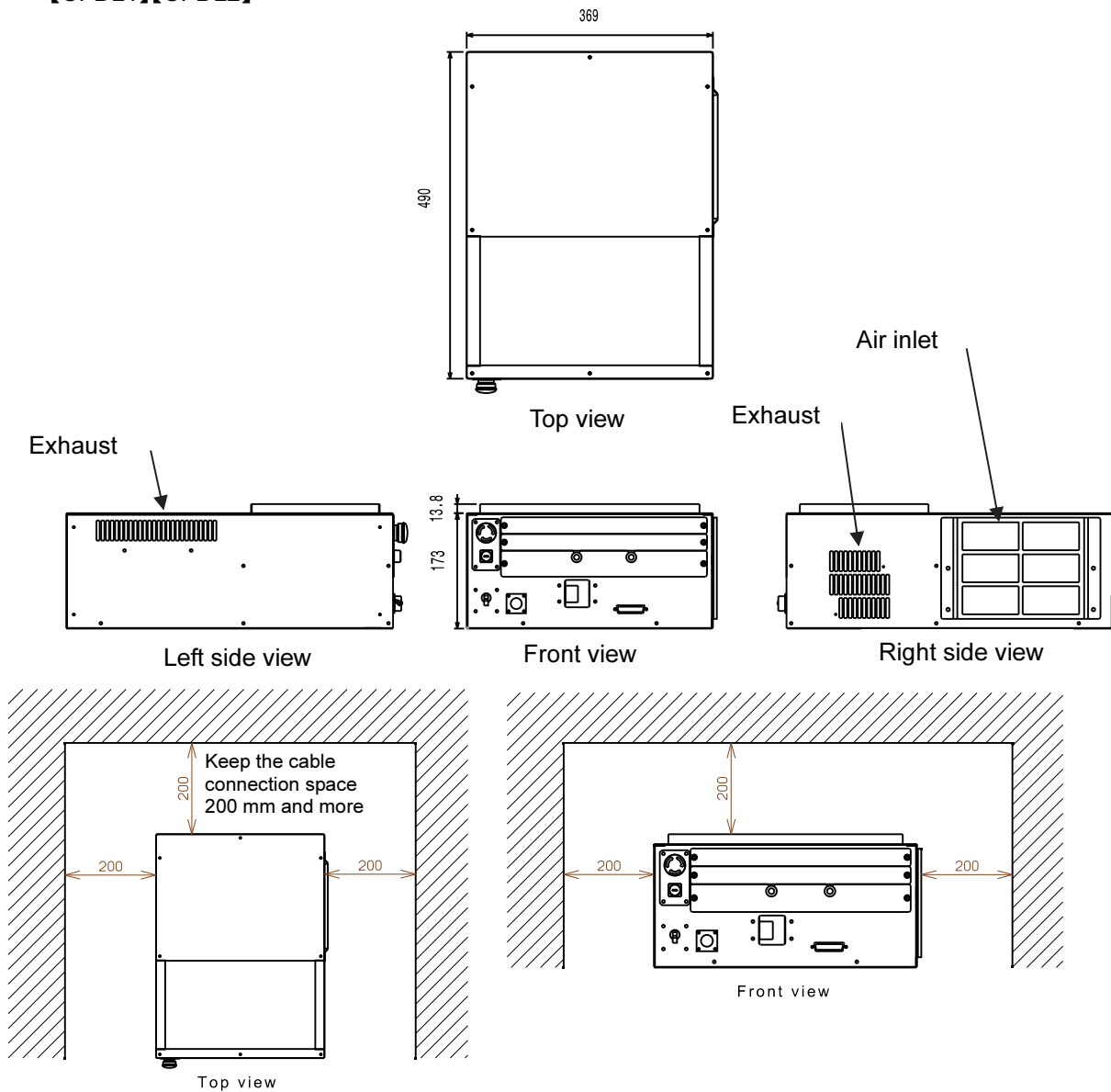

【CFDL4】

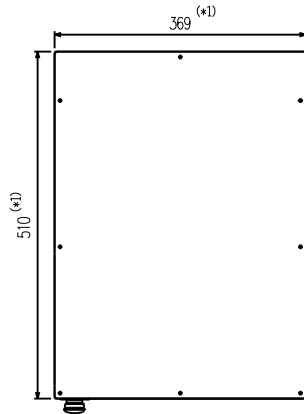

Top view

Exhaust

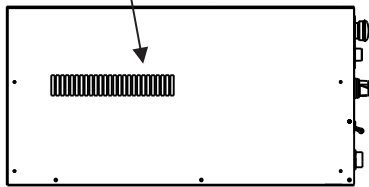

Left side view

Exhaust

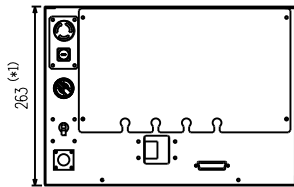

Front view

Air inlet

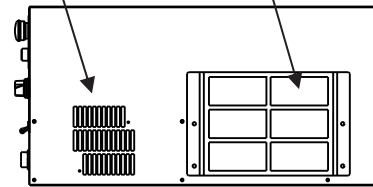

Right side view

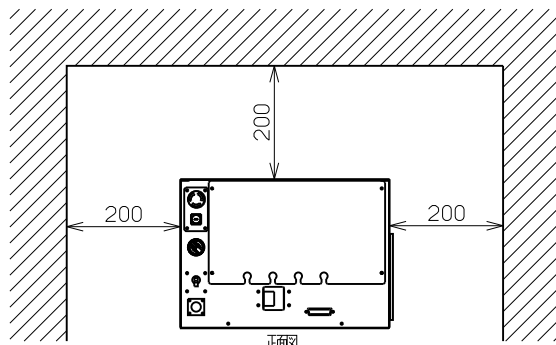
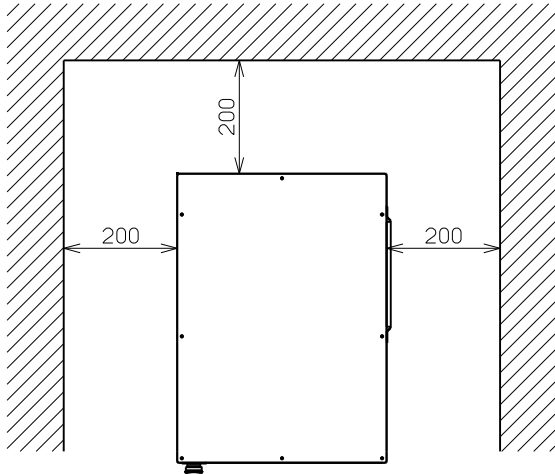

.....

6. Allowable wrist load



Load fixed on the tip of wrist is regulated by “allowable payload mass”, “allowable static load torque”, and “allowable moment of inertia”. Strictly keep the wrist load within each allowable value. If wrist load exceeds the allowable value, this robot is out of guarantee. Refer to the table of “2. Basic specifications” and following figures for the detail of each specification.

■ Torque map for wrist load

Use the robot under condition that COG of wrist load falls in the range shown in the torque map.

	Rated condition	Max.condition *1
<p>【EZ03V4-02-4525】 【EZ03V4-02-4515】 【EZ03F4-02-5525】 【EZ03F4-02-5515】</p>		
<p>【EZ02V6-02-4525】 【EZ02V6-02-4515】 【EZ02F6-02-5525】 【EZ02F6-02-5515】</p>		

*1: Speed and/or acceleration are automatically limited.

■ How to find the inertia moment

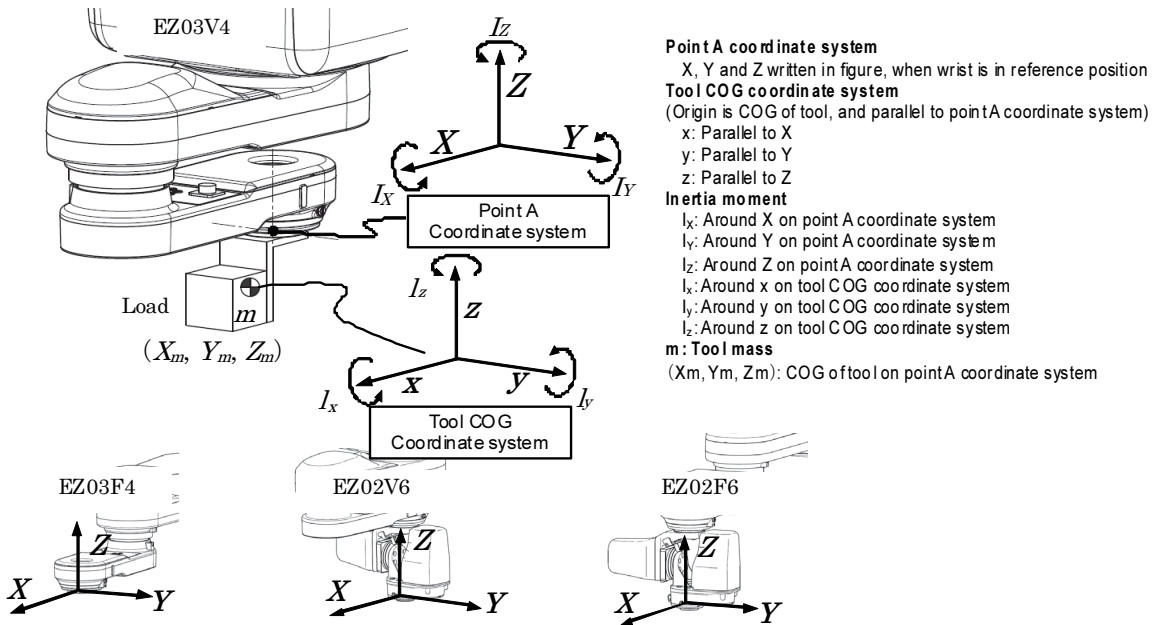

<p>1 Calculate inertia moment defined on tool COG coordinate system (xyz). If tool is regarded as prism, it is calculated as right formula.</p>	<p>Inertia moment example on tool COG coordinate system</p> <p>If tool is regarded as prism</p> $I_x = \frac{1}{12} m \cdot (A^2 + B^2)$ $I_y = \frac{1}{12} m \cdot (A^2 + C^2)$ $I_z = \frac{1}{12} m \cdot (B^2 + C^2)$ <p>These values (I_x, I_y, I_z) are registered to controller.</p> <p>Inertia moment on tool COG coordinate system</p> <p>This is different from "allowable moment of inertia" written in robot specification sheet.</p>
<p>2 Calculate inertia moment defined on point A coordinate system (XYZ), then calculate inertia moment around robot wrist joint (axis 4, 5 and 6). This result must not be larger than "Allowable moment of inertia" written in robot specification sheet.</p>	<p>Inertia moment on point A coordinate system (XYZ) is</p> $I_X = m \cdot (Y_m^2 + Z_m^2) + I_x$ $I_Y = m \cdot (X_m^2 + Z_m^2) + I_y$ $I_Z = m \cdot (X_m^2 + Y_m^2) + I_z$ <p>Axis 4 and 5 inertia moment is larger value of I_X and I_Y, because this depends on axis 6 position. Axis 6 inertia moment is I_Z itself.</p> $I_{J4} = I_{J5} = \max(I_X, I_Y)$ $I_{J6} = I_Z$

7. Application wiring and tube diagram

■ When installing Solenoid valve (option) (4 axis)

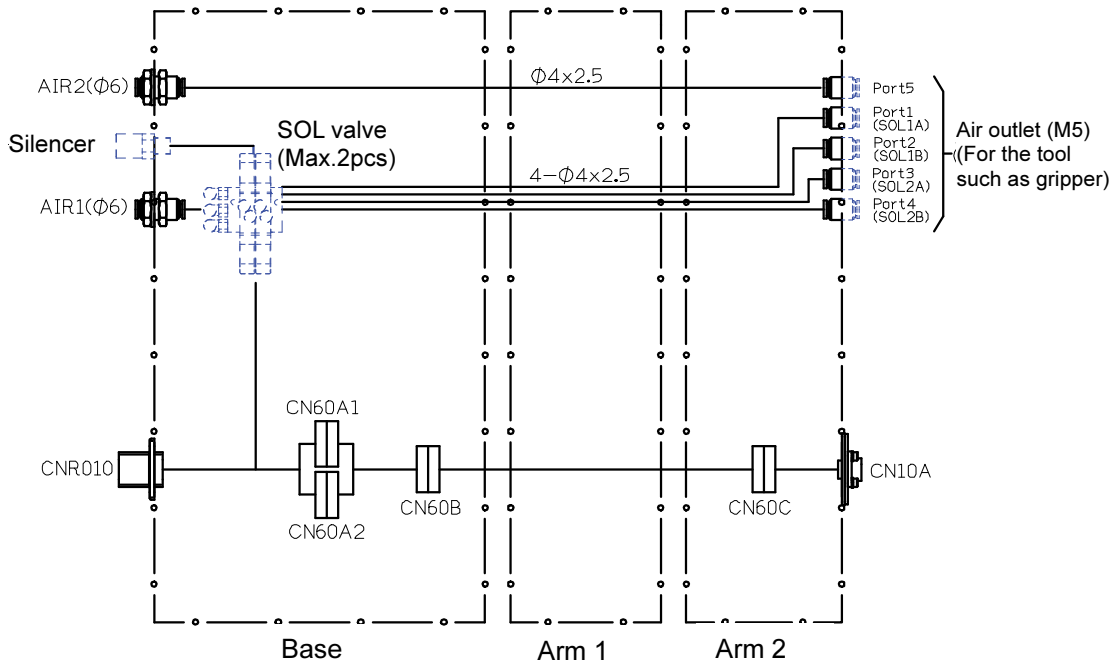

Solenoid valve storage part

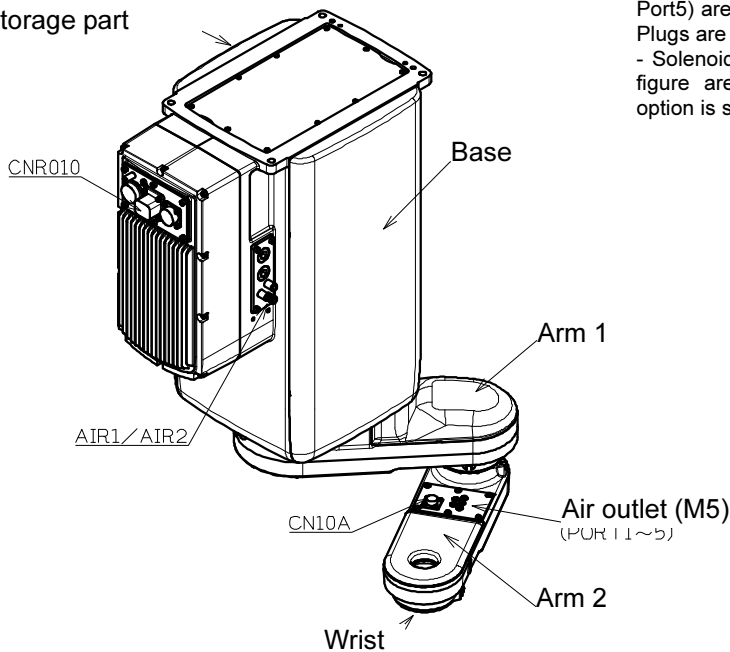

Caution

- Only 2 air lines (AIR1 to Port1 and AIR2 to Port5) are connected directly inside gear box. Plugs are attached on air outlet.
- Solenoid valves and silencer written in this figure are mounted when "solenoid valve" option is selected.

■ When installing Solenoid valve (option) (6 axis)

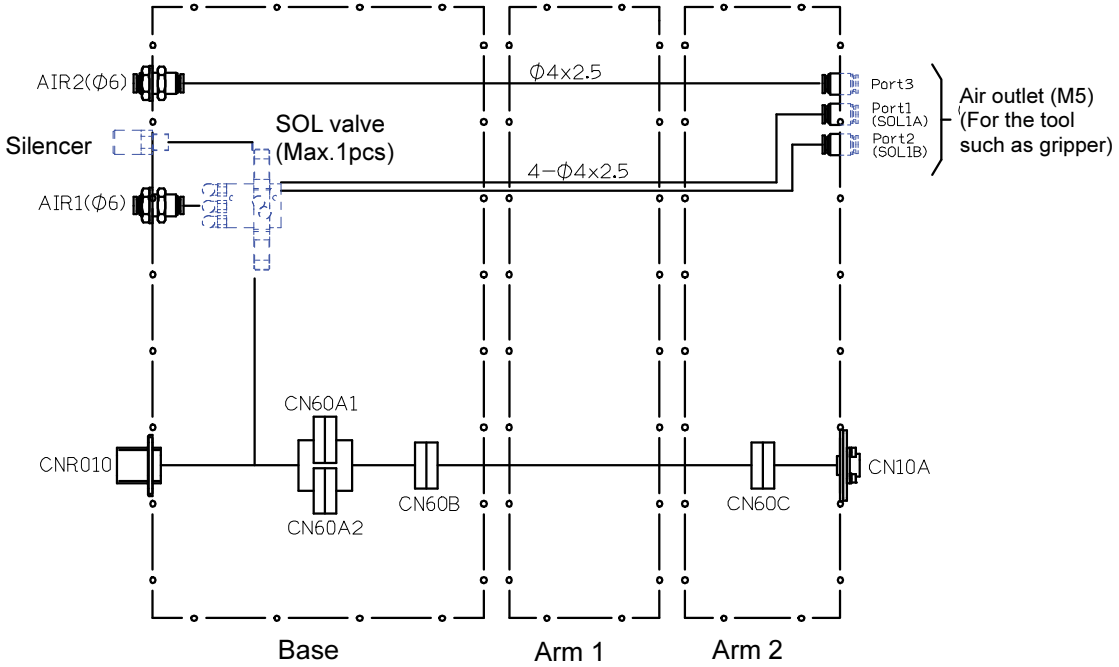

Solenoid valve storage part

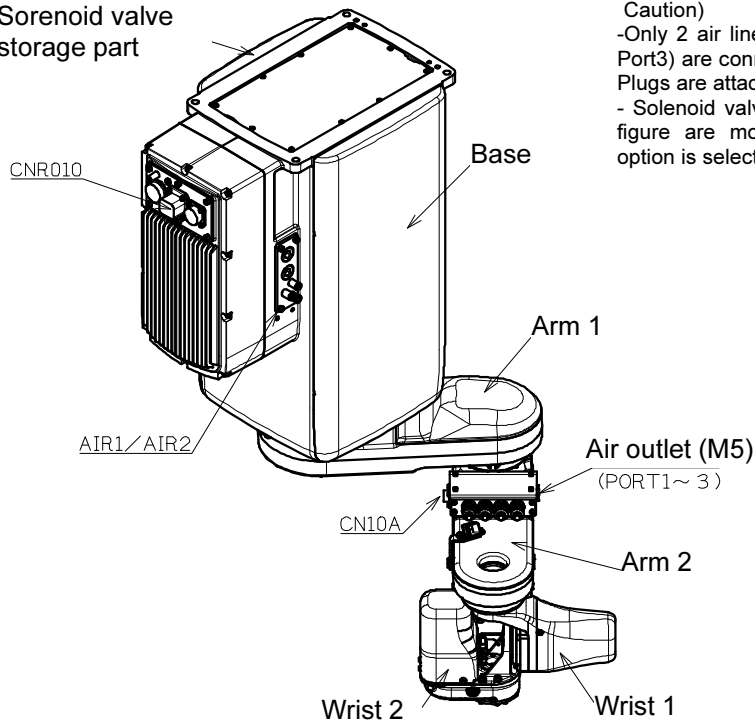

Caution)
 -Only 2 air lines (AIR1 to Port1 and AIR2 to Port3) are connected directly inside gear box. Plugs are attached on air outlet.
 - Solenoid valves and silencer written in this figure are mounted when "solenoid valve" option is selected.

■ Detailed diagram of the application connectors (4 axis)

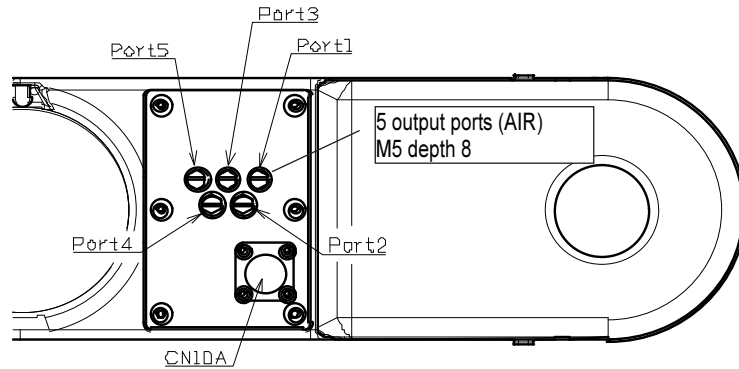

	6	5	4	3	2	1
D	G	A20	A19	A18	A17	A16
C		A15	A14	A13	A12	A11
B	A22	A10	A09	A08	A07	A06
A	A21	A05	A04	A03	A02	A01

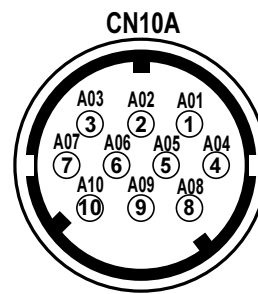

Connector CNR010 type on base
 Tyco AMP 1939839-1, 1939840-1, 1903112-2
 Partner connector type
 Tyco AMP 1939847-1, 1939850-1, 1827570-2

Connector CN10A on wrist 1
 JAE JN1AS10ML1-R
 Partner connector type
 JAE JN1DS10SL2

■ Detailed diagram of the application connectors (6 axis)

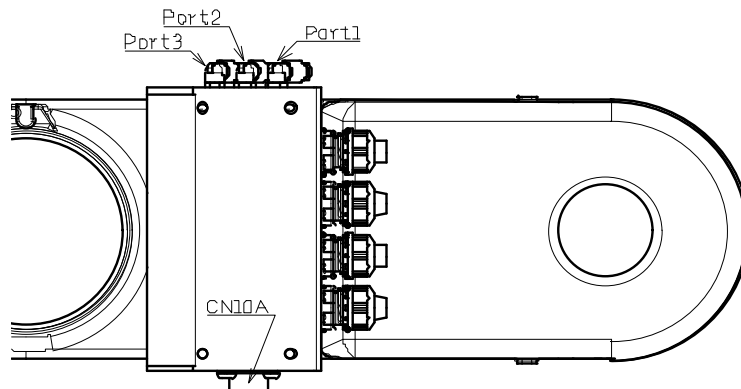

	6	5	4	3	2	1
D	G	A20	A19	A18	A17	A16
C		A15	A14	A13	A12	A11
B	A22	A10	A09	A08	A07	A06
A	A21	A05	A04	A03	A02	A01

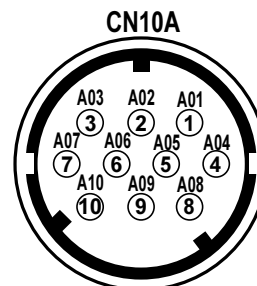

Connector CNR010 on base
 Tyco AMP 1939839-1, 1939840-1, 1903112-2
 Partner connector type
 Tyco AMP 1939847-1, 1939850-1, 1827570-2

Connector CN10A on wrist 1
 JAE JN1AS10ML1-R
 Partner connector type
 JAE JN1DS10SL2

8. Control specification

○; Supported, —; Setting disable (Execution enable), ×; Not supported

Functions	Functional description	Smart TP	Compact TP
Robot language	SLIM language is supported for complicate application.	○	—
Interpolation	Linear interpolation; Fixing TCP;	○	○
	Tool coordinate;		
	Circular interpolation;		
Low speed playback	TCP speed is limited 250mm/sec under following condition. 1. Low speed signal input 2. Check GO/BACK operation 3. First step playback after STEP number is designated	○	○
Speed definition	TCP linear speed 1 - 5000mm/sec (0.1mm/sec unit) Time 0.01 - 100sec (0.01sec unit) Power ratio 1.0 - 100.0 % (0.1% unit) Tool angle speed 1 - 500deg/s (1deg/s unit)	○	○
Speed override	Playback speed can be varied 1 - 150% without changing recorded speed.	○	○
Check GO/BACK	In teach mode, recorded position can be confirmed step by step or continuously, and forward / backward. (Functions also can be played back.)	○	○
Accuracy	8 degrees (0 - 1000mm) of in position accuracy can be designated on every step. And in-position or path-through can be designated also.	○	○
Tool designation	32 different tools can be designated on every step.	○	—
Automatic tool constant calculator	Tool length (TCP position), tool weight and COG and tool moment of inertia can be calculated automatically by designated program. (*3)	○	×
Self checking	Self check the error of robot and controller. (700 kind of errors)	○	○
Error detection	Check the condition of robot and controller all the time. Robot stops immediately when error happens.	○	○
Logical I/O	Maximum 2,048 logical inputs and 2,048 logical outputs are available as standard.	○	○
Signal assignment	Port assignment and positive/negative logic of all I/O is available.	○	—

(*1) This coordinate system is based on the "ISO 9787:1998, Manipulating industrial robots – Coordinate systems and motions"

(*2) In case of 4 axes specification robots, the motion direction is limited.

(*3) This is only for 6 axes specification robots. The 4 axes specification robots cannot use this function.

○; Supported, —; Setting disable (Execution enable), ×; Not supported

Functions	Functional description	Smart TP	Compact TP
Editor	Can perform correction, deletion and confirm of the created program. 1. Screen editor Addition, deletion and copy of every move step and function is available. (Recorded position can be also edited.) 2. Copy utility Recorded program and step can be copied. 3. Program conversion Condition & speed, each axis angle, parallel shift, etc. 4. Program Certification File directory, file verify	○	×
Machine lock	This can check I/O by playback program, keeping robot stationary.	○	○
I/O simulation	This can check program flow by changing logical I/O from teach pendant, keeping physical I/O locked.	○	○
Memory protect	This can protect program to avoid the modification and deletion by careless operation.	○	—
Power saver	This can save energy by motor power off and brake lock after pre-determined time passed with no movement. When more time passed, fan motors inside of the robot will stop for further power saving.	○	○
Monitor utility	Real time monitor of following data;	○	○
	1. Robot program	○	○
	2. Error logging	○	○
	3. Fixed I/O	○	—
	4. General usage I/O	○	○
	5. Program queue	○	—
6. Operating time etc.	○	—	
Help message (Built-in manual)	Operations and function explanations are displayed on teach pendant. And graphical troubleshooting manual is also displayed.	○	×
Customization	Software keys are re-locatable for better operation.	○	×
Power failure backup	When main power is down while playback robot, all necessary data is back upped for easy restarting of the robot after power on. (Save the data, which was just before the power outage occurs.)	○	○
Program queue	Up to 10 programs to be played back can be stored.	○	—
Home position	Up to 32 home positions can be defined. Home position signal is outputted.	○	—
Function commands	<ul style="list-style-type: none"> • General usage signal output • General usage signal input • Program flow control (step jump/call, program jump/call) • Timer delay • Shift instruction etc. 	○	○

○; Supported, —; Setting disable (Execution enable), ×; Not supported

Functions	Functional discription	Smart TP	Compact TP
Interface panel	Pushbuttons and lamps can be arranged on teach pendant touch panel screen. Operating switches and indicators are replaced to software, so this utility can contribute to cost down. Available to register up to 31 keys /screen * 15 screens = 465 keys	○	×
Ethernet	File upload and download via Ethernet is available. (1 port)	○	○
Software PLC	This is sequencer, which is built-in controller type. Use I/O part of the optional board for input and output. (Refer to hardware option)	○	—
High Speed Interference Detection	In the case operation mistake or unexpected interference occurs during teaching work, this function can detect the collision between tool and peripheral equipments, and stops the robot immediately.	○	○
Overhaul Prediction	This is to prevent from trouble occurrence by estimating the lifespan of bearings in each robot arm and by detecting torque over. Furthermore, this function can predict the overhaul timing of robot.	○	—
Palletizing	Palletizing and de-palletizing teaching can be programmed by easy pattern definition.	○	—
Adaptive motion control	Enabling to drive each joint with flexibility.	○	—
Oscilloscope	Enabling to monitor the servo data such as velocity, current, etc. of each joint by graphical display on teach pendant.	○	—
Fine motion control	Enabling to improve the locus accuracy. Command is recorded in step.	○	—
User Task	Task program can be executed separately from robot program.	○	—
Language	English Japanese Chinese Korean Germany Italian Spanish	○	× (*)

(*) Japanese is KANA characters. Chinese is Pin-In alphabetic characters. Other language is in English.

9. Options

■ Option List

○; Supported, ×; Not supported, —; Irrelevant with controller type

No.	Item	specification	Parts No	Controller type					Remarks
				CFDL1-0000	CFDL2-0000	CFDL4-0000	CFDL4-0200	CFDL4-0300	
1	Adjustable stopper	For 2 axis	OP-S5-032	-	-	-	-	-	
2	Transfer jig	For crane and ceiling-jig transporting	OP-S2-049	-	-	-	-	-	
3	Tools	Zeroing pin & block (For 4 axis robot)	OP-T2-099	-	-	-	-	-	For 1 to 4 axis
		Zeroing pin & block (For 6 axis robot)	OP-T2-094	-	-	-	-	-	For 1 to 6 axis
4	Solenoid valve	1 valve	OP-H4-009	-	-	-	-	-	Pressure : 0.1 to 0.5 MPa Coil voltage : DC24V
		2 valves (only for 4 axis type)	OP-H5-011	-	-	-	-	-	
5	Wires clamp	Wiring/ piping clamp of 4 axis hollow (only for 4 axis type)	OP-W3-018	-	-	-	-	-	Air (φ4:5 lines), signals
6	USB memory	1GByte	FD11-OP93-A	○	○	○	○	○	Select one among left.
		4GByte	FD11-OP93-B	○	○	○	○	○	
7	Mini I/O board	8 points/ 8 points (Relay output)	—	-	-	-	-	-	Mounted on sequence board as a standard.
8	Digital I/O Board	I/O 32 points /32 points (NPN 1 board)	CFD-OP125-A	○	○	○	○	○	Occupies 1 slot ※
		I/O 64 points /64 points (NPN 2 boards)	CFD-OP125-B	○	×	×	○	○	Occupies 2 slots ※ Select one among CFD-OP125-*
		I/O 32 points /32 points (PNP 1 board)	CFD-OP151-A	○	○	○	○	○	Occupies 1 slot ※
		I/O 64 points /64 points (PNP 2 boards)	CFD-OP151-B	○	×	×	○	○	Occupies 2 slots ※ Select one among CFD-OP151-*
9	EthernetIP	Master 1CH	CFD-OP130-A	○	○	○	○	○	Occupies 1 slot ※ Select one among left.
		Slave 1CH	CFD-OP130-B	○	○	○	○	○	
		Master 1CH+Slave 1CH	CFD-OP130-C	○	○	○	○	○	
		Slave 2CH	CFD-OP130-D	○	○	○	○	○	
		Master 2CH	CFD-OP130-E	○	○	○	○	○	
10	DeviceNet board	Master 1CH	CFD-OP131-A	○	○	○	○	○	Occupies 1 slot ※ Select one among left.
		Slave 1CH	CFD-OP131-B	○	○	○	○	○	
		Master 1CH+Slave 1CH	CFD-OP131-C	○	○	○	○	○	
		Slave 2CH	CFD-OP131-D	○	○	○	○	○	
		Master 2CH	CFD-OP131-E	○	○	○	○	○	
11	DeviceNet board (Quick specification) connect	Master 1CH	CFD-OP129-A	○	○	○	○	○	Occupies 1 slot ※ Select one among left.
		Slave 1CH	CFD-OP129-B	○	○	○	○	○	
		Master 1CH+Slave 1CH	CFD-OP129-C	○	○	○	○	○	
		Slave 2CH	CFD-OP129-D	○	○	○	○	○	
		Master 2CH	CFD-OP129-E	○	○	○	○	○	
12	PROFIBUS board	Master 1CH	CFD-OP132-A	○	○	○	○	○	Occupies 1 slot ※ Select one among left.
		Slave 1CH	CFD-OP132-B	○	○	○	○	○	
		Master 1CH+Slave 1CH	CFD-OP132-C	○	○	○	○	○	
		Slave 2CH	CFD-OP132-D	○	○	○	○	○	
		Master 2CH	CFD-OP132-E	○	○	○	○	○	
13	PROFINET board	Slave 1CH	CFD-OP136-B	○	○	○	○	○	Occupies 1 slot ※ Select one among left.
		Slave 2CH	CFD-OP136-D	○	○	○	○	○	
14	CC-Link	Master + Slave 1CH	CFD-OP98-B	○	○	○	○	○	Occupies 1 slot ※
15	FL-net	1CH	CFD-OP101-C	○	○	○	○	○	Occupies 1 slot ※
16	Analog output	Analog output 4CH	CFD-OP46-B	○	○	○	○	○	Occupies 1 slot ※
17	Conveyor synchronization interface	RS422 differential input encoder counter	CFD-OP47-A	○	○	○	○	○	Occupies 1 slot ※

○; Supported, ×; Not supported, -; Irrelevant with controller type

No.	Item	specification	Parts No	Controller type					Remarks
				CFDL1-0000	CFDL2-0000	CFDL4-0000	CFDL4-0200	CFDL4-0300	
18	Controller protection box	Protection level IP54 support (Add Dust / Drew-proof BOX)	CFDL-OP133-A	○	○	×	×	×	CFDL1, CFDL2
19	UL specification	ULstandard support	CFDL-UL-A	○	×	×	×	×	
	CE specification	CE marking support	CFDL-CE-A	○	○	×	×	×	
			CFDL-CE-B	○	×	×	×	×	Controller type is CFDL1-0010. Select one among CFDL-CE-*
			CFDL4-CE-A	×	×	○	○	○	
KCs specification	Korea KCs support	CFDL-KCS-A	○	○	○	○	○		
20	Smart TP	Cable length 4m	CFDTP-10-04M	-	-	-	-	-	This is an option. Select one among left.
21	Mini TP	Cable length 4m	MINITP-10-04M	-	-	-	-	-	
22	TP shorting plug	Using when disconnecting to TP.	CFD-OP153-A	-	-	-	-	-	
23	TP extention cable	5m	CFDTP-RC05M	-	-	-	-	-	Extention is up to one cable. Both sides are connector. Select one among left.
		10m	CFDTP-RC10M	-	-	-	-	-	
24	Motor / Encoder harness	2m	E000E-J1-02-B	-	-	-	-	-	Cable to connect robot and the controller. Must select option. Select one among left.
		5m	E000E-J1-05-B	-	-	-	-	-	
		10m	E000E-J1-10-B	-	-	-	-	-	
		15m	E000E-J1-15-B	-	-	-	-	-	
		20m	E000E-J1-20-B	-	-	-	-	-	
25	CNR010 I/O harness (Robot side-Connector connection Controller side-separated wires)	2.5m	IOCABLE-10-02M	-	-	-	-	-	I/O cable between robot and controller. Controller side is separate cable. Manufacturing needs to be done by customer. Select one among left.
		5.5m	IOCABLE-10-05M	-	-	-	-	-	
		10.5m	IOCABLE-10-10M	-	-	-	-	-	
		15.5m	IOCABLE-10-15M	-	-	-	-	-	
		20.5m	IOCABLE-10-20M	-	-	-	-	-	
		25.5m	IOCABLE-10-25M	-	-	-	-	-	
26	CNR010 I/O harness Relay output support (Robot / controller side-Both side is connector)	2.5m	IOCABLE-40B-02M	-	-	-	-	-	I/O cable, which connecting to sequence I/O board between robot and controller. Select one among left.
		5.5m	IOCABLE-40B-05M	-	-	-	-	-	
		10.5m	IOCABLE-40B-10M	-	-	-	-	-	
		15.5m	IOCABLE-40B-15M	-	-	-	-	-	
		20.5m	IOCABLE-40B-20M	-	-	-	-	-	
		25.5m	IOCABLE-40B-25M	-	-	-	-	-	
27	I/O cable on robot arm	1.5m	IOCABLE-20-01M	-	-	-	-	-	
28	I/O connector on robot arm	Connector only. Soldering type	IOCABLE-20-00	-	-	-	-	-	
29	32 points I/O harness (Controller side-connector Application side-separated wires) One additional I/O board	2.5m	IOCABLE-30-1-02M	-	-	-	-	-	Customer need to conduct wiring to application side. Available by CFD-OP-125-A CFD-OP-151-A Select one among left.
		5.5m	IOCABLE-30-1-05M	-	-	-	-	-	
		10.5m	IOCABLE-30-1-10M	-	-	-	-	-	
		15.5m	IOCABLE-30-1-15M	-	-	-	-	-	
		20.5m	IOCABLE-30-1-20M	-	-	-	-	-	
		25.5m	IOCABLE-30-1-25M	-	-	-	-	-	
30	64 points I/O harness (Controller side-connector Application side-separated wires) Two additional I/O boards	2.5m	IOCABLE-30-2-02M	-	-	-	-	-	Customer need to conduct wiring to application side. Available by CFD-OP-125-B CFD-OP-151-B Select one among left.
		5.5m	IOCABLE-30-2-05M	-	-	-	-	-	
		10.5m	IOCABLE-30-2-10M	-	-	-	-	-	
		15.5m	IOCABLE-30-2-15M	-	-	-	-	-	
		20.5m	IOCABLE-30-2-20M	-	-	-	-	-	
		25.5m	IOCABLE-30-2-25M	-	-	-	-	-	

○; Supported, ×; Not supported, -; Irrelevant with controller type

No.	Item	specification	Parts No	Controller type					Remarks
				CFDL1-0000	CFDL2-0000	CFDL4-0000	CFDL4-0200	CFDL4-0300	
31	Power voltage alteration	For AC100V portable transformer	CFD-OP154-A						1-2 robot specification
			CFDL-OP154-A						4 robots specification Select one among CFD*-OP154*.

DeviceNet and EtherNet/IP is a trademark of ODVA (Open DeviceNet Vendor Association, Inc.).
 CC-Link is a trademark of CC-Link Partner Association : CLPA.
 PROFIBUS and PROFINET is a trademark of PROFIBUS & PROFINET International.

- 4: Solenoid valve- Model SYJ3220-5GR-M3 (SMC), 2 positions double solenoid, Coil voltage DC24V, Consuming power 0.35W, With surge voltage protector circuit (no pole), No-lock push type manual operation, Without sub-plate for tube, Without bracket
Number of the valves depends on the specification. Refer "1. Outline" also.
- 5: Frange 1, Frange 2, Cramp and 4 bolts (M5x20), and a positioning pin MDP-5x25. For details, refer to the instruction manual "CFD CONTROLLER TECHNICAL DOCUMENT 1" (TCFEN-155).
- 6: USB memory: Used to backup program and constant files. Insertion port is on the front panel as standard.
- 8: Additional I/O Board
 Photo coupler input; DC24V no pole, Input resistance 3KΩ/8mA
 NPN Transistor output; DC24V NPN, output voltage DC36V output current 100mA
 PNP Transistor output; DC24V PNP, output voltage DC36V output current 100mA
 Relay output; DC24V Relay contact output voltage DC30V output current 500mA
- 9,11,12,13,14 and 15: Each Fieldbus board / Available up to 4 channels. Maximum channel quantity may vary according to Fieldbus specification and combination with other options.
- 17: Conveyor synchronization I/F- To perform conveyor synchronized motion, speed signal receiver board is added. Differential input (conforming to RS-422), Terminating register 100Ω (set by SW on board), Response frequency 1MHz at maximum.
- 18: Controller protection BOX can upgrade the protective level of the CFDL controller from IP20 (standard spec.) to IP54.
- 21: Compact TP- FD on Desk Light is necessary for setup.
- 22: TP shorting plug- When disconnecting the teach pendant from the CFD controller, connect this shorting plug instead of the teach pendant (The emergency stop lines are jumpered). While this plug is connected, manual operation of the robot and teaching operation is impossible. And, to playback (start) the work-program, it is necessary to input the external signals from an external PLC etc.
- 23: Teach pendant extension cable- Diameter φ5.8mm, minimum bending radius 35mm
- 25: I/O harness- Robot side connector CNR010 (assembled) is included. Cable diameter φ10.5mm, minimum bending radius 65mm
- 26: I/O harness- Both side connectors are included. Cable diameter φ10.5mm, minimum bending radius 65mm
- 27,28: I/O cable on robot arm and connector - These option parts are the same with that of MZ series.
- 29,30: These are the cables that can be used for CFD-OP125 and CFD-OP151. The controller side connectors are pre-assembled.
- 31: Power voltage alteration- This is a transformer unit to change the power source voltage to 100VAC. The cable between the CFDL controller and the transformer unit must be prepared by customer. (The connector is included in this option) Because there are several robots that can not be used with this option, please contact our technical department in advance.

※ CFDL1 / CFDL2 / CFDL4 controller has a limitation of the number of available optional slots. The number of robots also affects the number of available optional slots. And, for example, the optional cards like "Digital I/O", "Fieldbus (e.g. CC-Link)", or "Conveyor synchronization I/F", etc. can be attached to any slot shown in the following table.

Model	Number of robots to be connected	Number of PCI option slots
CFDL1-0000	1	2
CFDL2-0000	2	1
CFDL4-0200	2	3
CFDL4-0300	3	2
CFDL4-0000	4	1

(Supplement) For example, in case of (1) "Conveyor synchronization I/F" card plus the (2) "CC-Link" card are to be used, because at least 2 slots are required, CFDL1-0000 or CFDL4-0020 is necessary.

■ FlexGui (only for Smart Teach Pendant)

The “FlexGui” is a function in which “Fidget” like buttons, indicators, digital displays etc, can be placed on the teach pendant screen. And it is also possible to use those fidgets with scripts and robot variables. By using this function, it becomes possible not only to make a simple and easy GUI on the teach pendant screen but also to construct a highly integrated operation panel on the screen without expensive hardware. Please use this function to reduce the cost and to make the operation interface of the robot more simple.

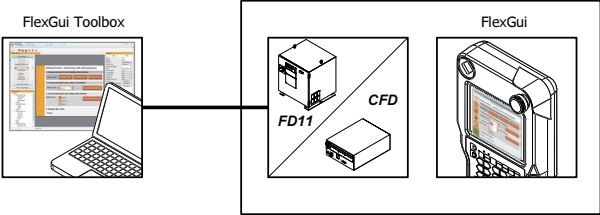
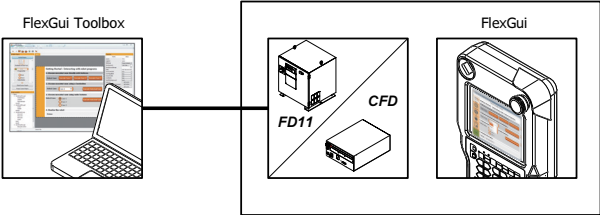
Product name (License name)	Description	Free / Charged	License file
No name (Demonstration version)	<p>This is a trial version of the FlexGui that is pre-installed in the robot controller when shipping. Created GUI screen file cannot be saved. FlexGui</p> 	Not necessary	Not necessary
FlexGui	<p>Created screen is saved when disconnecting to power supply. It is possible to transfer the GUI screen file (that is created using the “FlexGui Toolbox”^(NOTE) on the PC) to the robot controllers by connecting Ethernet. In case there are several controllers, it is necessary to get licence files to each controller.</p> 	Necessary	Necessary
FlexGui Remote	<p>The PC, which operates FlexGui Toolbox, corresponds with the controller then, it is possible to operate the controller from PC. In case there are several controllers, it is necessary to get licence files to each controller. (Only key input of the screen can be operated. Robot cannot be operated.)</p> 	Necessary	<p>Necessary (When using FlexGui Remote, FlexGui licence is necessary.)</p>

(NOTE) FlexGui Toolbox can be downloaded from www.flexgui.net



- If the license file is necessary, please contact our sales department in advance of ordering the robot controller.
- When purchasing a license file after the controller, it is necessary to get the “FlexGui ID” displayed on the teach pendant screen.

■ **Instruction**

No	Item	Specification
1	Instruction manual	Offers instructions of basic operation and initial setting of the robot with PDF format (DVD). For improvement, the content of this disc may be changed without notification.

10. Delivery style and service (specification which includes a robot)

1. There are three styles as shown below.

	Style and service	Details
1	Delivery on the truck	Robot is delivered on the truck near the entrance of customer's plant. (Installation and test-run is not included)
2	Installation and test-run	Robot is installed and test-run is done. (Teaching with work piece is not included.)
3	Installation and teaching with work piece	Besides style 2, teaching with work piece is done.

Price may vary largely depends on which style and service to choose, therefore please consider well before making a decision.

2. Operation and maintenance education

Special operation and preservation guide in your local city/ country are not included. Please consult with NACHI-FUJIKOSHI service center close from your location for training and etc.

11. Consuming power (Robot + Controller)

0.6 kVA at maximum (may vary according to the application and motion pattern.)

12. Paint color (Robot and controller)





Standard color	Robot body	Munsell 6.5PB9/1
	Controller	Munsell N1.5

13. Warranty

1 year after delivery.

The specification and externals described in this specification might change without a previous notice for the improvement.

14. Cautions

 CAUTION	<p>There is a case that the wrist vibration occurs when operating with low speed, even setting the wrist load correctly, depending on the motion and the tool shape of robot. This occurs because of the arm drive system vibration and natural frequency of the arm come close to each other.</p> <p>It is possible to make the vibration small by shifting resonance point followed by the method below in that case.</p> <ul style="list-style-type: none"> • Change recorded speed of the robot program • Change tool weight and inertia moment • Change robot posture
 CAUTION	<p>There is a case that vibration, overload and execution error can occur depending on the motion and/ or loading condition when start-up under low temperature.</p> <p>In that case, conduct break-in about 10 min w/ 30% override, and speed up gradually.</p>
 CAUTION	<p>In case of transporting the arm without fixing, there's a possibility to damage the robot by vibration or impact during transportation.</p> <p>Please make sure to equip the arm fixing bracket, which was installed at shipping when transporting the robot.</p>
 CAUTION	<p>Overhaul period of robot itself is either 4 years or 20,000 Hr. (Choose shortest one.) This overhaul period is calculated by the motion pattern of NACHI standard, therefore durability may decline depends on operating condition of the customer.</p> <p>It is recommended to operate 50% of cycle time duty as a operation guide to meet the overhaul period above.</p> <p>*Cycle time duty: The ratio of operation time during 1 cycle. Stop time of the robot includes arm halt during hand operation and waiting till next cycle.</p>

NOTE

NACHI NACHI-FUJIKOSHI CORP.		http://www.nachi-fujikoshi.co.jp/	
Japan Main Office	Phone: +81-3-5568-5245	Fax: +81-3-5568-5236	Shiodome Sumitomo Bldg. 17F, 1-9-2 Higashi-Shinbashi Minato-ku, TOKYO, 105-0021 JAPAN
Nachi Robotic Systems Inc. (NRS)		http://www.nachirobotics.com/	
North America Headquarters	Phone: 248-305-6545	Fax: 248-305-6542	42775 W. 9 Mile Rd. Novi, Michigan 48375, U.S.A
Indiana Service Center	Phone: 248-305-6545	Fax: 248-305-6542	Greenwood, Indiana
Ohio Service Center	Phone: 248-305-6545	Fax: 248-305-6542	Cincinnati, Ohio
South Carolina Service Center	Phone: 248-305-6545	Fax: 248-305-6542	Greenville, South Carolina
Canada Branch Office	Phone: 905-760-9542	Fax: 905-760-9477	89 Courtland Ave., Unit No.2, Concord, Ontario, L4K 3T4, CANADA
Mexico Branch Office	Phone :+52-555312-6556	Fax:+52-55-5312-7248	Urbina No.54, Parque Industrial Naucalpan, Naucalpan de Juarez, Estado de Mexico C.P. 53489, MEXICO
NACHI EUROPE GmbH		http://www.nachi.de/	
Central Office Germany	Phone: +49-2151-65046-0	Fax: +49-2151-65046-90	Bischofstrasse 99, 47809, Krefeld, GERMANY
U.K. branch	Phone: +44-0121-423-5000	Fax: +44-0121-421-7520	Unit 3, 92, Kettles Wood Drive, Woodgate Business Park, Birmingham B32 3DB, U.K.
Czech branch	Phone: + 420-255-734-000	Fax: +420-255-734-001	Obchodni 132, 251 01 Cestice, PRAGUE-EAST CZECH REPUBLIC
Turkey branch	Phone: + 90-(0)216-688-4457	Fax: +90-(0)216-688-4458	Ataturk Mah. Mustafa Kemal Cad. No:10/1A 34758 Atasehir / Istanbul - TURKEY
NACHI AUSTRALIA PTY. LTD.		http://www.nachi.com.au/	
Robotic Division & Victoria office	Phone: +61-(0)3-9796-4144	Fax: +61-(0)3-9796-3899	38, Melverton Drive, Hallam, Victoria 3803, AUSTRALIA
Sydney office	Phone: +61-(0)2-9898-1511	Fax: +61-(0)2-9898-1678	Unit 1, 23-29 South Street, Rydalmere, N.S.W, 2116, AUSTRALIA
Brisbane office	Phone: +61-(0)7-3272-4714	Fax: +61-(0)7-3272-5324	7/96 Gardens Dr,Willawong,QLD 4110, AUSTRALIA
NACHI SHANGHAI CO., LTD.		http://www.nachi.com.cn/	
Shanghai office	Phone: +86-(0)21-6915-2200	Fax: +86-(0)21-6915-2200	11F Royal Wealth Centre, No.7 Lane 98 Danba Road Putuo District, Shanghai 200062, China
NACHI KOREA		http://www.nachi-korea.co.kr/	
Seoul office	Phone: +82-(0)2-469-2254	Fax: +82-(0)2-469-2264	2F Dongsan Bldg. 276-4, Sungsu 2GA-3DONG, Sungdong-ku, Seoul 133-123, KOREA

Copyright NACHI-FUJIKOSHI CORP.

Robot Division

1-1-1, FUJIKOSHIHONMACHI, TOYAMA CITY, JAPAN 930-8511

Phone +81-76-423-5137

Fax +81-76-493-5252

NACHI-FUJIKOSHI CORP. holds all rights of this document. No part of this manual may be photocopied or reproduced in any form without prior written consent from NACHI-FUJIKOSHI CORP. Contents of this document may be modified without notice. Any missing page or erratic pagination in this document will be replaced.

In case that an end user uses this product for military purpose or production of weapon, this product may be liable for the subject of export restriction stipulated in the Foreign Exchange and Foreign Trade Control Law. Please go through careful investigation and necessary formalities for export.

Original manual is written in Japanese.

NACHI-FUJIKOSHI CORP. ©