

Boosting Stepper Motor Performance: Position Control on a Budget

Low-cost stepper motors are an attractive alternative to high-end servomotors for many industrial motion control applications. This has been made possible by a new generation of kit encoders (modular position sensors) that can be quickly and easily added to standard motors, providing accurate and reliable closed-loop position control. As well as providing absolute position measurements, these new sensors offer self-powered, maintenance-free multi-turn functionality. This paper, describes ways of bringing stepper motor performance closer to servo motors levels by adding feedback devices.

Join our Network!





WHITE PAPER

Stepper Motor Basics

Stepper motors are simple brushless DC motors that are used in a wide range of applications, from small tools and appliances to vehicles and manufacturing equipment. In the industrial arena, they have been used for positioning tasks in manufacturing equipment and for high-speed pick & place processes. Compared to servomotors, which are designed for precision motion control, stepper motors are simpler and much less expensive, averaging one tenth the cost of equivalently sized servomotors!

With stepper motors, control is achieved through the incremental rotation of the electromagnetic field generated by the motor's stator coils. Stepper motor operation depends on a **controller** – an electronic device that feeds current to the motor's stator coils in a sequence that drives step motions. With each signal from the controller, the rotor moves by a clearly defined step or angular offset. 200 steps per revolution is common, although motors with 400 or more steps are available. The capabilities of the controller will have a significant impact on motor performance. A resolution of less than 0.1 degrees can be achieved by micro-step operation.

There are several types of stepper motors available, with the most widely used varieties offering good resolution, good low-speed torque, rugged construction, long service life and relatively low cost. There are, however, limitations. Torque output drops off at higher rotational speeds and with simple controllers, stepper motors can be subject to ringing (high frequency vibrations) as the motor moves abruptly between step positions.

Stepper Motors for Position Control

While stepper motors can be very useful for position control tasks, it is important to realize that, in their basic

form, stepper motors operate in an open-loop control mode. Stepper motors respond to an instruction from their controller to move a certain number of steps but provide no feedback to the controller as to whether this motion has been completed. If the motor fails to complete the requested number of step motions, there can be a growing discrepancy between what the controller *understands* as the rotary position of the motor shaft and the *true* position of the shaft and the mechanism it is driving. This can happen when the torque generated by the motor is insufficient to overcome mechanical resistance and can become a significant problem at higher rotation speeds when torque output is reduced. To avoid this, stepper motors are often over-specified for the task they are intended to perform, meaning larger, heavier motors. As well, when the motor comes to a stop, current is required to flow through the motor windings to hold the stepper motor shaft in position. This results in a warm motor and extra power consumption.

Adding Feedback

Adding feedback can close the control loop by providing information about the true shaft position. While feedback devices add to system cost, the combination may still be much less expensive than servomotor alternatives.

One approach for adding feedback is to operate in “move-and-verify” mode. In this case, a simple incremental encoder is added to the tail shaft of a stepper motor, with a resolution that is typically a multiple of 200 positions per revolution. In this mode, when the controller issues step commands to the motor, the encoder detects the motion and sends a signal to verify that it has taken place. If the motor fails to complete the requested number of steps, the controller can request more steps until the motor ends up in the intended position. More sophisticated controllers increase the



WHITE PAPER

phase current to the motor, boosting torque for the extra steps. With move-and-verify, it may still be a good idea to use oversized motors, but not to the degree required with simple open-loop systems. When the motor shaft is stopped in position, intelligent controllers may be able to fine tune the holding currents to an appropriate level. However, stepper motor phase currents – and overall energy consumption – still tend to be high.

Closed Loop Control

For critical position control applications, full closed loop control based on multiturn absolute encoders can be a better choice. This type of encoder would be attached to a stepper motor's tail shaft to monitor absolute rotation angle and rotation count. In this configuration, the stepper motor is controlled like a high pole-count brushless DC (BLDC) motor, with the encoder providing position feedback to the controller. When the stepper motor is controlled like a BLDC motor, the 'holding' current supplied to the motor can be limited to the amount required to maintain position within a given position tolerance. A stepper motor controlled like a brushless servo motor is energy efficient and less expensive than a true BLDC servo motor. So, why not use low-cost stepper motors for all BLDC servo applications? Stepper motors used in closed loop servo systems will still have physical limitation when compared with 'true' BLDC servo motors. A stepper motor operated this manner would be, in effect, a 50-pole brushless motor. This will limit operating speeds (RPM). Also, the rotor of a stepper motor has higher inertia than a true BLDC servo motor of equivalent power, so acceleration is limited.

When a stepper motor is used in BLDC mode, the encoder performs a vital **commutation** role, reporting the exact rotary position of the motor shaft so that the controller can energize that appropriate set of

stator electromagnets for continuous rotation when this is called for. Precision absolute encoders can also be used with advanced microstepping controllers to fine-tune the phase current to reduce the ringing (vibration) encountered with more basic stepper motor installations.

Choosing the Right Encoder

As was mentioned above, simple **incremental** encoders can be effective when a stepper motor is used in move-and-verify mode. They can also be used when speed control is the primary objective, although stepper motors are not usually the best choice for continuous operation at steady speeds.

Absolute encoders, which report the shaft's rotary position, are ideal for critical position control tasks. These are available in self-contained (with their own closed housing and shaft) or kit forms. While self-contained encoders require some form of coupler to connect them to the motor's shaft, kit or modular encoders are designed to be integrated into a motor or drive mechanism, measuring rotary motion directly from the drive shaft. Kit encoders might be built into the motor's housing or attached externally to a motor's end bell.

Optical Encoders: Optical measurement technology is used for both incremental and absolute encoders. The key components of an optical encoder are a "code disk", installed on the rotating shaft, an LED light source, and an array of photoreceptors. The disk is made of transparent material and carries a concentric pattern of transparent and opaque areas. The disk sits between the light source and the photoreceptors so that the pattern of light falling on the photoreceptors will change as the disk rotates. Signals from the photoreceptors are combined to provide an accurate measure of the rate of

rotation and/or the rotation angle of the shaft.

Encoders based on optical measurement technologies are available in a range of configurations and performance levels. At the high end, precision absolute optical measurement systems can have accuracies of +/- 0.02 degree or better and very good dynamic response. These are suitable for advanced servomotors and precision position control applications.

At the other end of the price/performance scale, some manufacturers offer low-cost incremental encoders based on optical measurement technology. While these have lower precision, they can be useful for providing feedback for inexpensive stepper motors operating in 'move and verify' mode.

While optical encoders can offer excellent performance, code disks and photoreceptors are vulnerable to

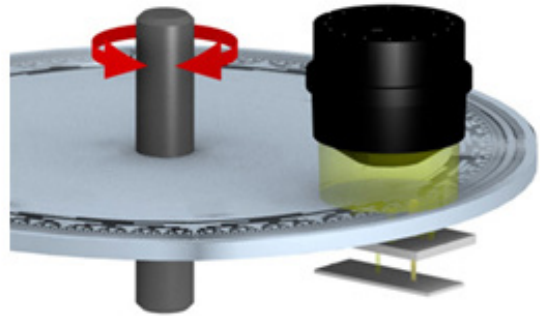

Optical Encoder

contamination from dust, oil and condensation. As well, to achieve maximum accuracy, code disks and photoreceptor arrays must be aligned very precisely. This can involve special assembly procedures carried out under near clean-room conditions. Optical code disks must have relatively large diameters – up to 50mm

Incremental or Absolute Measurements

Incremental encoders send a stream of signal pulses to the controller as the device's shaft rotates. The pulse rate is equal to the rotational speed times the device's resolution, expressed as the number of pulses per rotation (PPR). Most incremental encoders also report the direction of rotation.

Incremental encoders are ideal for speed control since they provide a real-time reading of the rate of rotation. Incremental encoders can also be used for positioning tasks, with the control system tracking the absolute position by counting the number of pulses received from the encoder. However, for positioning systems built around incremental encoders, this position count could be lost or corrupted during a power failure or system

shutdown. In this case, it may be necessary to return the machinery to a known reference position and re-start the position count before operations can resume.

Absolute encoders provide a snapshot reading of the shaft's angle of rotation, usually as a multi-byte digital 'word', in response to a request from the system's controller. For multi-turn absolute encoders, the output combines the angle of rotation with a count of the number of complete rotations that the encoder shaft has experienced. Absolute encoders are ideal for positioning tasks, since most can report their complete absolute rotational position (including the number of complete turns) immediately on startup. This eliminates the position-reset problem encountered with incremental encoders.

WHITE PAPER

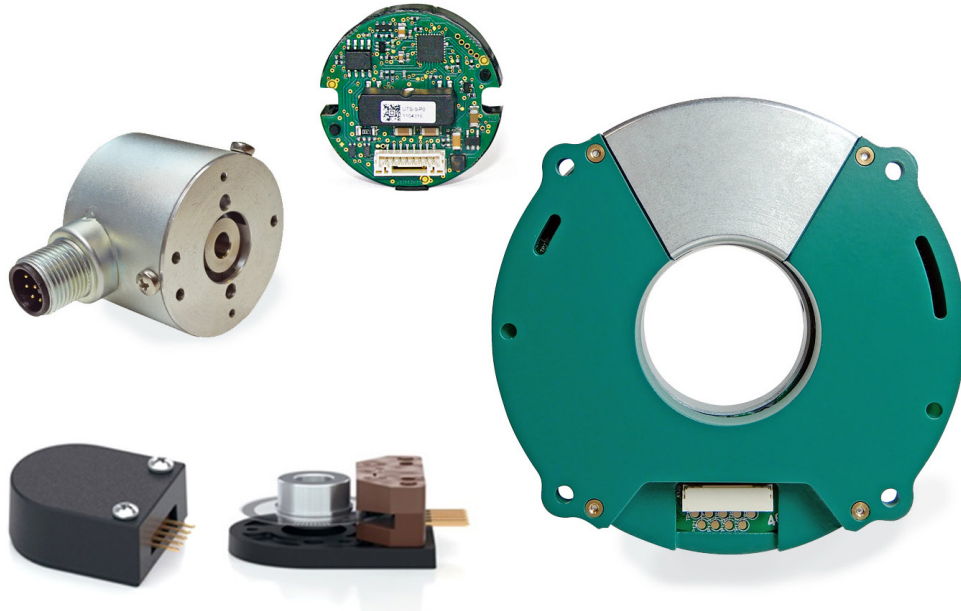

Kit Encoders: Magnetic, Capacitive and Optical Variants

– in order to achieve high resolutions. This means that high-accuracy versions of these instruments will be relatively large.

Magnetic Encoders, which measure rotations through a set of Hall-effect sensors, are an attractive option for feedback control of stepper motors. Available in self-contained or kit form, they are robust, relatively insensitive to dust, moisture and other contaminants, and easy to install.

Magnetic kit encoders consist of an electronics package, mounted on a small PCB, along with a small permanent magnet array attached to the rotating shaft. Since kit encoders do not have the housings, shafts, bearings, or seals required for self-contained encoders, manufacturers can deliver the core measurement module at relatively low prices. As a result, stepper motor-encoder combinations are typically much less expensive than comparable servomotors. Cost

efficiency also extends to the steps required to install magnetic kit encoders in a stepper motor's housing. The magnetic measurement technology is relatively tolerant to minor misalignment between the rotating element (a small permanent magnet fastened to the motor shaft) and the components bolted to the housing. This simplifies assembly procedures and reduces manufacturing costs. A self-calibrating feature can compensate for minor alignment errors with no loss of measurement accuracy.

Magnetic kit encoder packages are available that have the same mounting form factor as many popular incremental encoders for NEMA standard stepper motors. The magnetic measurement module is compact (37 mm diameter, 23 mm deep) and highly resistant to dust, moisture, and shock/vibration loading. Shields are available to protect the measurement module from external magnetic fields (e.g. motor brakes). Accuracies

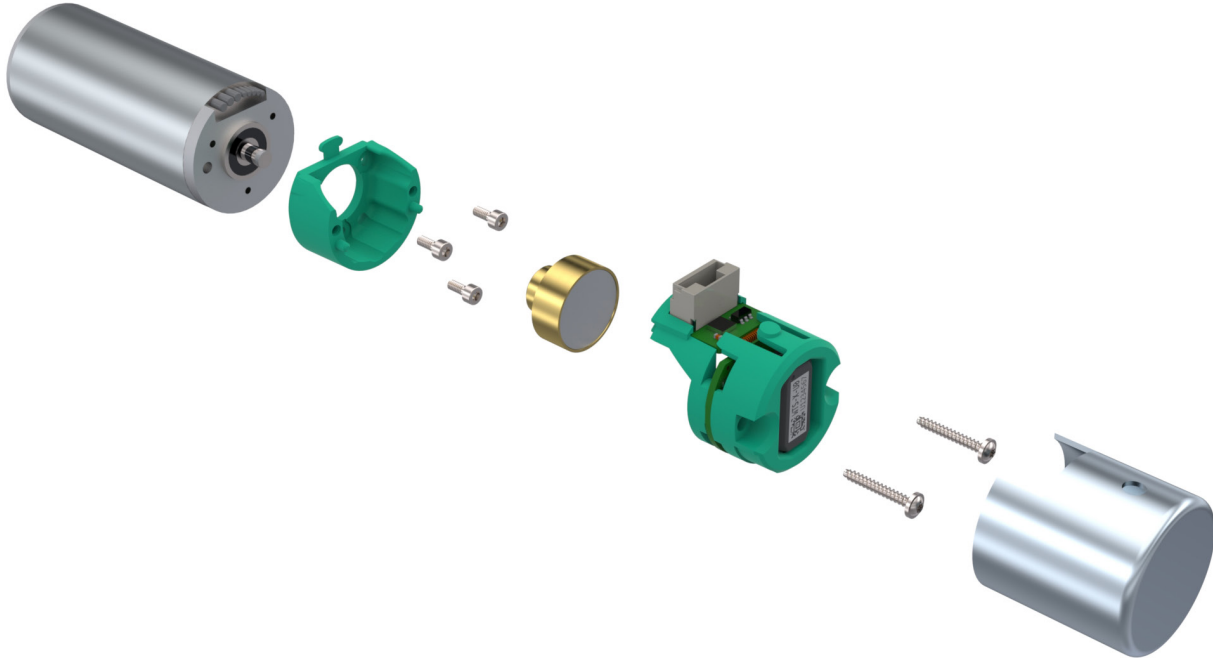

22 mm Encoder Installed on a Miniature Stepper Motor

are generally adequate for stepper motor installations.

Kit encoders are available with SSI and the more advanced “BiSS C” communication interfaces. Both are open-source interfaces that are compatible with a wide range of PLC’s and computers.

For smaller motors, miniature encoders are available. These have an external diameter of 22 mm and a length of 23 mm, but share the same resolution, dynamic response and multiturn measurement capabilities as their larger counterparts.

Hollow Shaft Kit Encoders: Most of the encoders discussed so far have position sensing elements located at the center of the device. While this is satisfactory for many applications, there are situations where designers would prefer to use measurement devices that fit around a central shaft, axle or structural

element. For stepper motors or drives, for example, it can be convenient to measure shaft rotation with a position sensor that fits around the drive shaft, rather than be attached at the opposite end of the casing. Hollow shaft (ring-shaped) encoders are designed to meet these requirements and give designers extra flexibility when configuring motion control systems.

Hollow shaft encoders are usually based on capacitive measurement systems. These can offer excellent accuracy ($\pm 0.02^\circ$) and dynamic response (up to 6000 RPM), making them suitable for use in critical motion control systems. Capacitive encoders are relatively tolerant of minor alignment errors between the stator and rotor and can be installed in motor housings or other types of equipment under reasonably clean factory conditions. They are relatively tolerant of dust and moisture, both during assembly and in operation and largely immune to magnetic fields. They can,

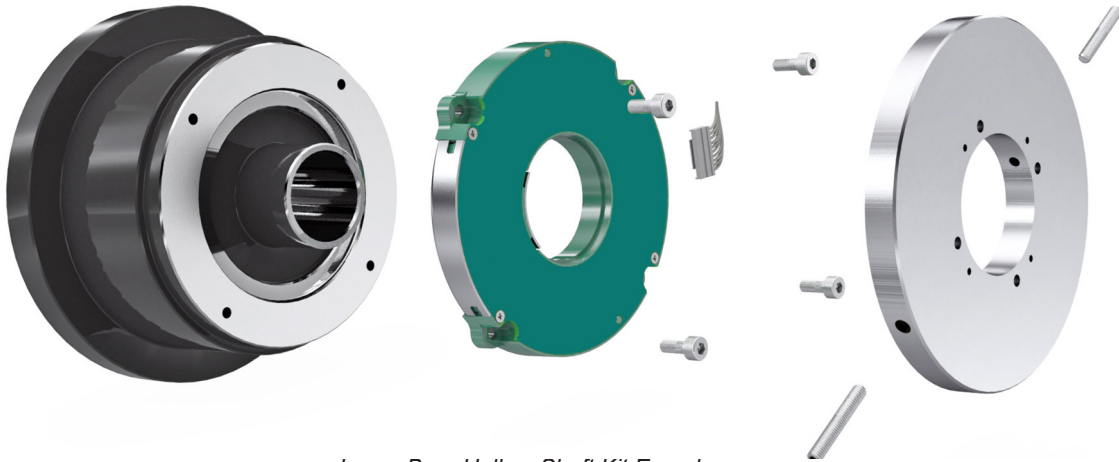
*Large-Bore Hollow-Shaft Kit Encoder*

however, be sensitive to strong electrical fields, so that shielding is generally recommended.

Multiturn Measurements

For servomotors or drives, multi-turn measurement capabilities can be useful for monitoring the position of mechanical components when, for example, a motor drives a screw shaft, a cable drum or a reduction gear system.

For most optical encoders, multiturn measurements are enabled by adding a series of secondary code disks, geared together so that each successive disk in the train rotates at a fraction of the rate of the disk driving it. While this system has been used successfully, it is costly and mechanically complex.

Multiturn magnetic encoders typically use some form of electronic rotation counter. This retains the

mechanical simplicity that is a key characteristic of magnetic measurement technology. However, for electronic counters, it is important to ensure that they can maintain an accurate count of the number of complete revolutions that the device has experienced, even if these rotations occur when instrument power is not available. (If a rotation counter fails to record every mechanical revolution, positional accuracy can be lost. In this case, it may be necessary to “re-home” the system by returning the entire machine to a known reference state and re-initiating the rotation count.) To ensure accurate position counts under all operating conditions, some encoder manufacturers include a backup battery to keep the rotation counter energized when instrument power is unavailable.

Encoder manufacturer POSITAL has developed an innovative approach to powering the electronic rotation counters on its magnetic and capacitive kit encoders.



WHITE PAPER

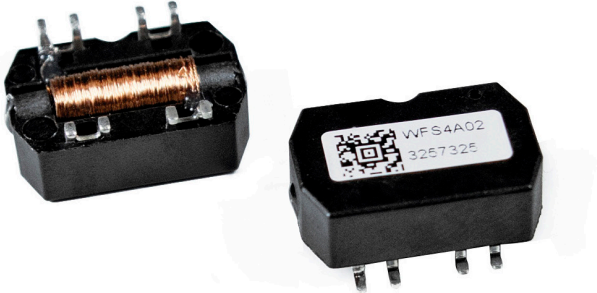

Wiegand Energy Harvesting Assemblies

The rotation counting system is self-powered. With each shaft rotation, pulses of electricity are created by a **Wiegand wire** system mounted on the encoder. This current pulse provides enough energy to activate the rotation counter, incrementing/decrementing the count stored in a non-volatile memory chip. This energy harvesting system operates independently of any external power source and ensures that each shaft rotation is registered reliably under any operating condition. By eliminating backup batteries, this system

reduces system complexity, device size, downtime, and maintenance costs. It also avoids the need to collect and dispose of spent batteries.

This system is available on both magnetic and hollow-shaft capacitive encoders.

Summary

Feedback-controlled stepper motors are not a complete substitute for servomotors, but for many real-world applications, they can provide a reliable alternative that will improve machine performance without breaking the bank!

Cologne (EMEA) – Hamilton NJ (Americas) – Singapore (APAC) – Shanghai (China)