

XRL Series

Cross Roller Linear Motor Stage

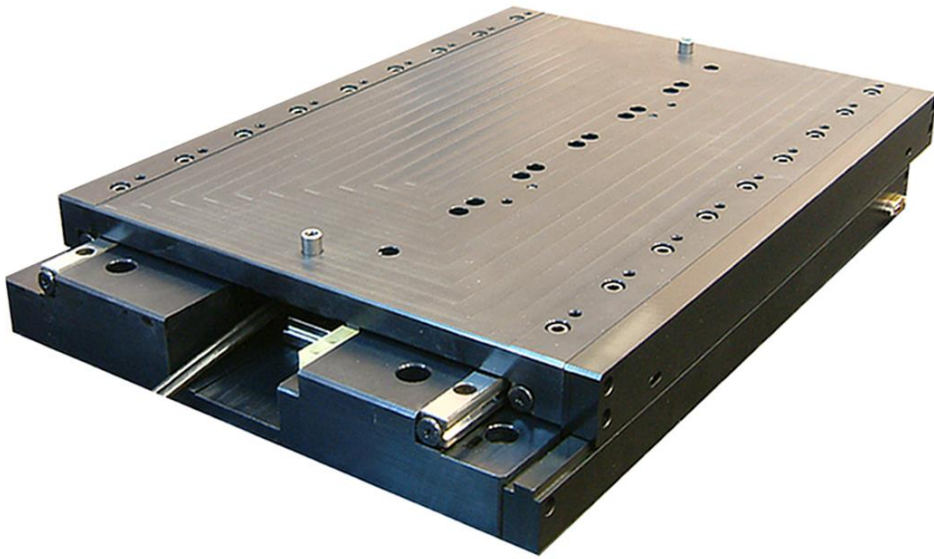

- Direct Drive
- Zero cogging and backlash ironless linear motor actuator
- Low friction
- Suitable for minute movement and smooth motion
- Fast response and quick settling time
- High Precision

XRL250 Series

Features

- Direct drive and direct measurement
- Fast response and quick settling time
- Zero cogging ironless linear motor
- No backlash
- Choice of encoder resolution up to 0.005 um with glass scale
- High precision anti creep cross roller guide offer low friction and low noise operation

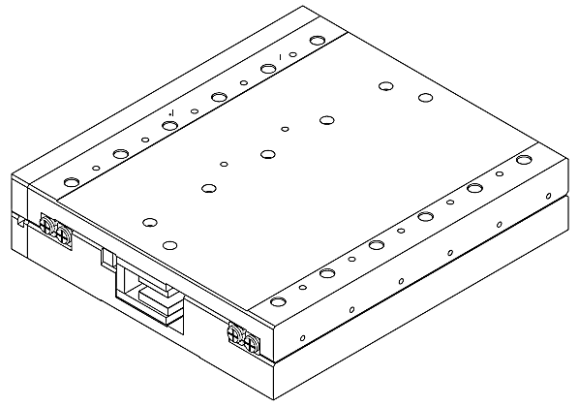

Motor Parameter

Specifications		AUM3-S2		AUM3-S3	
Performance Parameters	Unit	Series	Parallel	Series	Parallel
Continuous Force, coil @100°C	N	57		85	
Peak Force	N	289		433	
Motor Constant	N/SqRt(W)	10.2		12.5	
Continuous Power	W	30.5		45.7	
Peak Power	W	796.0		1193.0	
Electrical Cycle	mm	60		60	
Max Bus Voltage	V	330		330	
Max Coil Temperature	°C	125		125	
Thermal Dissipation Constant	W/°C	0.41		0.61	
Continuous Current	Arms	1.8	3.6	1.8	3.6
Peak Current	Arms	9.2	18.4	9.2	18.4
Force Constant	N/Arms	31.4	15.7	47.1	23.6
Back EMF Constant	Vpeak/(m/s)	25.6	12.8	38.5	19.2
Inductance	mH	6.26	1.57	9.39	2.35
Terminal Resistance @25°C	Ohms	9.40	2.35	14.10	3.53
Electrical Time Constant	ms	0.67	0.67	0.67	0.67
Mechanical Parameters					
Coil Mass	Kg	0.45		0.68	
Coil Length	mm	121		181	
Track Mass (per 120 mm)	Kg	1.00			
Magnetic Attraction	N (lb)	0			

Dimensional Drawing

XRL 250-S2-150, XRL 250-S3-100

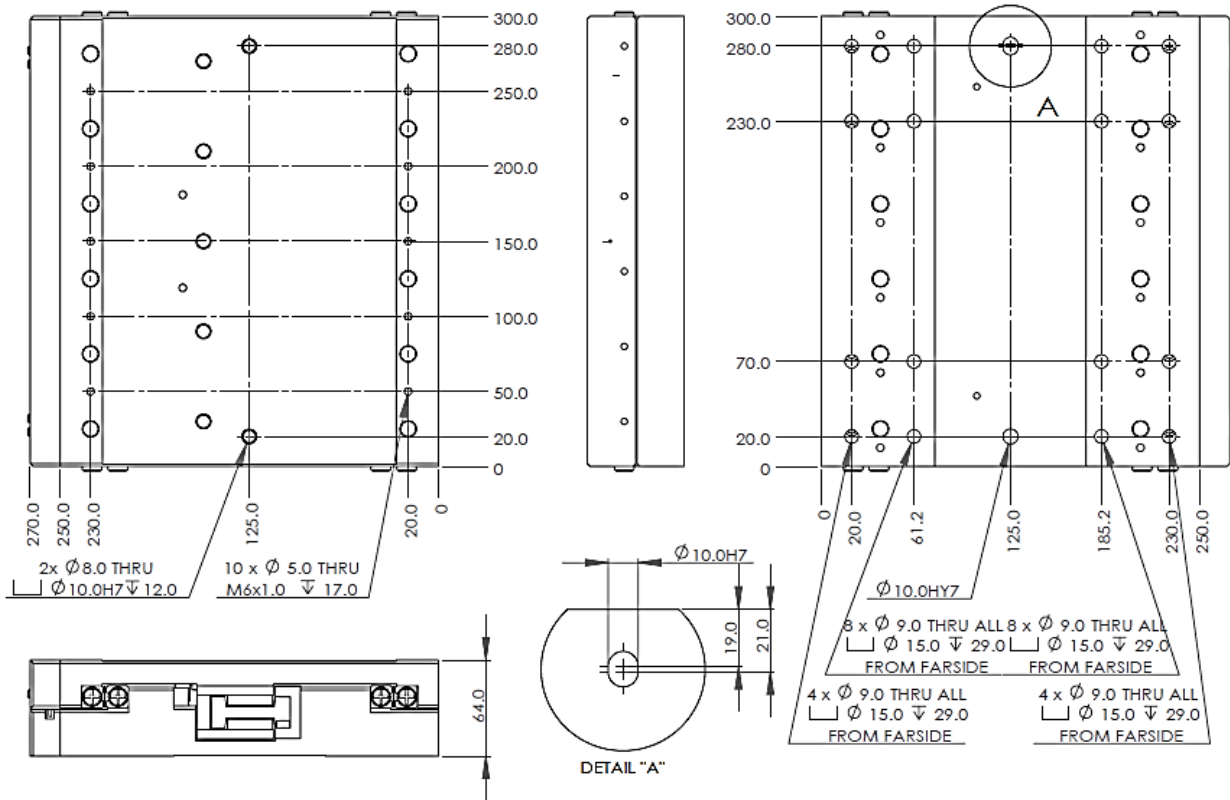

XRL 250-S2-200, XRL 250-S3-160

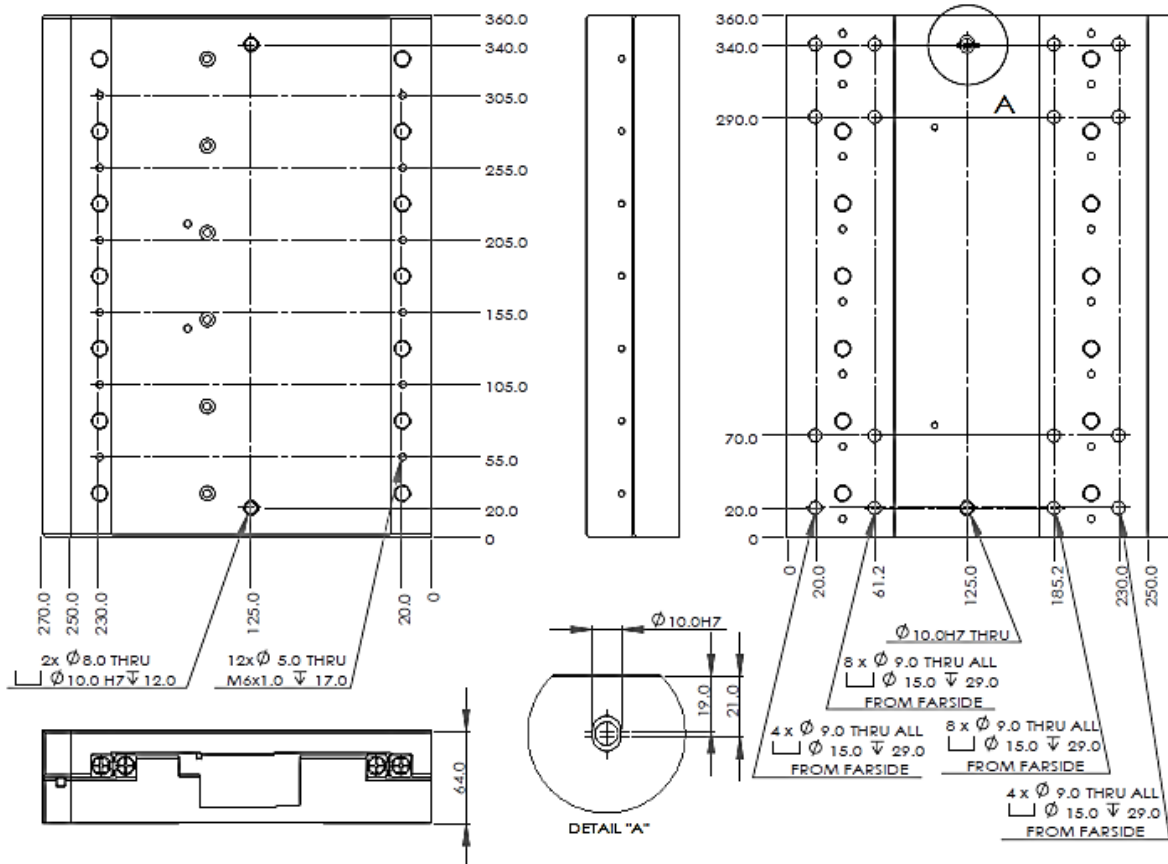

Model	Coil Type	Effective Stroke (Z) (mm)	Overall Length (X)	Moving Mass (Kg)	Module Mass (Kg)
XRL 250	S2	150	300	6.3	14.2
		200	360	7.5	16.9
XRL 250	S3	100	300	6.6	14.5
		160	360	7.8	17.2

Bearing Parameters

Specifications	Unit	S2	S3
XRL 250- S2-150, XRL 250-S3-100			
Maximum bearing load	N	5010	5010
Recommended row moment	Nm	956	956
Recommended pitch moment	Nm	901	901
Recommended yaw moment	Nm	901	901
XRL 250-S3-200, XRL 250-S3-160			
Maximum bearing load	N	5630	5630
Recommended row moment	Nm	1075	1075
Recommended pitch moment	Nm	1294	1294
Recommended yaw moment	Nm	1294	1294

Geometrical Parameter

Specifications	Unit	S2
Straightness	um	+/-1um/25mm
Flatness	um	+/-1um/25mm
Bidirectional repeatability	um	+/- 2 counts

Part Numbering (Rapid Delivery Series)

XRL 250	Motor (type)	Connection Type	Motor Size	Sensor Type	Cable Length (m)	Cable Version	Effective Stroke	Encoder Option (type)	Encoder Resolution	
									(um)	
	AUM3	P,S	S2,S3	J, K	3.0	V3	¹ 150 – 200	RE, M1	RE	*M1
									0.1,1,5	1500-1.0 / 1500-0.5
										2000-0.1
										3000-0.02
										3500-0.005

1. For customized stroke length , please contact us.
2. For applications that have specific straightness and flatness requirements, precision class (P) is available.
Please contact us for more details.
3. With external Micro Photo sensor (Panasonic PM Series)

Example: XRL250-AUM3-S-S2-J-3.0-V3-200-M1-1500-0.5

X-Y STACK FOR XRL250 SERIES

Dimension Drawing

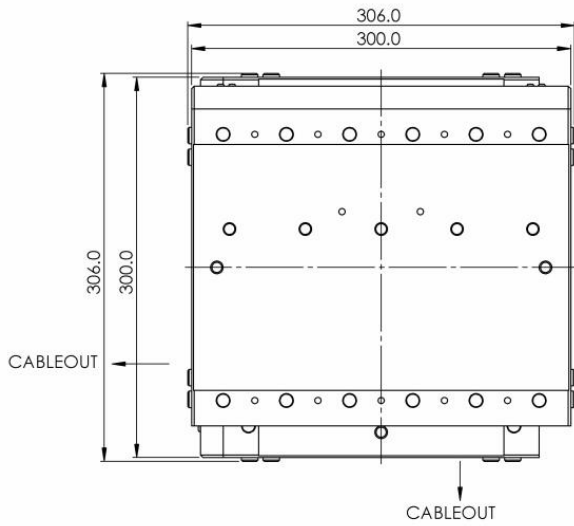

XRL250 STROKE = 100mm OR 150mm
X-Y STROKE AT MID POSITION

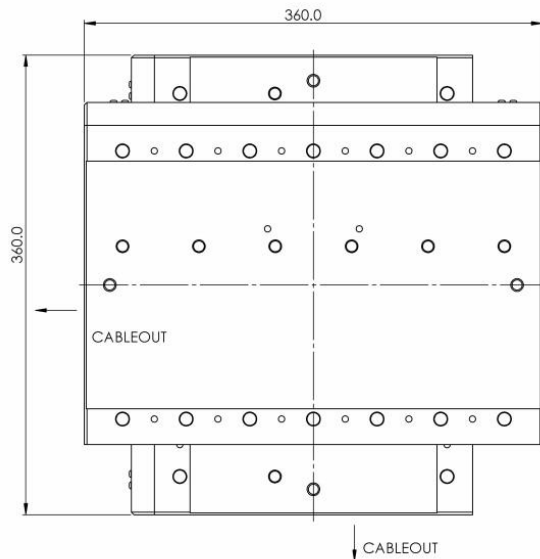
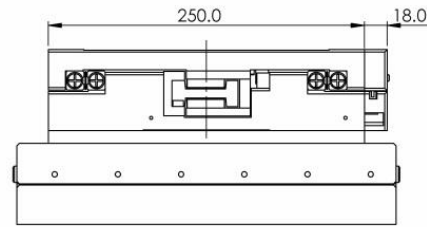
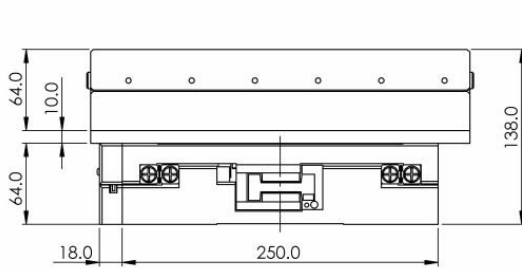

XRL250 STROKE = 160mm OR 200mm
X-Y STROKE AT MID POSITION

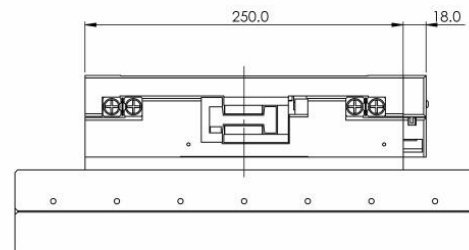
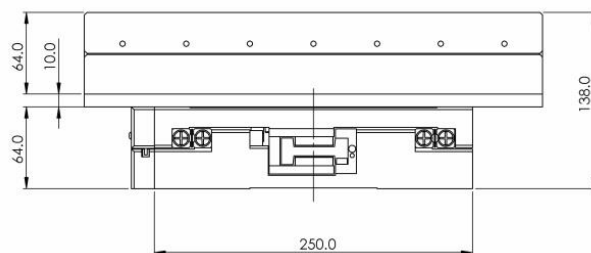

Part Numbering (Rapid Delivery Series)

XRL	Bottom Axis (X)	Top Axis (Y)
	XRL250 Part Number	XRL250 Part Number

Example: XRL-X-XRL250-AUM3-S-S2-J-3.0-V3-150-M1-1500-0.5

XRL-Y-XRL250-AUM3-S-S2-J-3.0-V3-150-M1-1500-0.5